

USER'S MANUAL  
**MSHF**  
MAST CLIMBING WORK PLATFORM

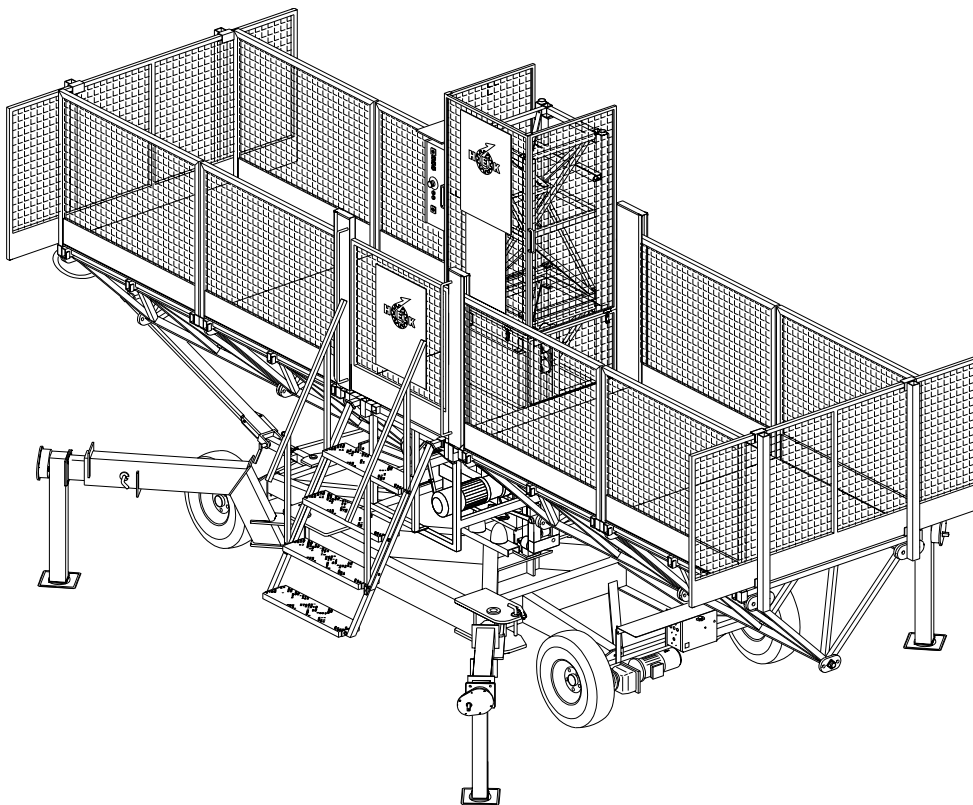

This manual is assigned to:

© 2000, HEK Manufacturing B.V., Middelbeers, The Netherlands

Nothing contained in this publication may be copied, and/or published by means of printing, photocopying, microfilm or any other method without prior written permission from HEK Manufacturing B.V.



---

**HEK Manufacturing B.V.**

Westelbeersedijk 18  
5091 SM Middelbeers  
The Netherlands

Tel : +31 13 51 48 653  
Fax : +31 13 51 48 630

P.O. box 2  
5090 AA Middelbeers  
The Netherlands



## FOREWORD

The mast climbing work platform is provided with a rack and pinion drive.

The mast climbing work platform can be quickly moved and is easy to transport.

The mast climbing work platform can be fitted with one or two masts and can be freestanding or anchored.

The mast, which consists of separate elements, can easily be adjusted in height to match the height of the building work. The mast is easy to assemble from the platform.

The platform can be adjusted to the shape of the façade.

The MSHF mast climbing work platform has a control system which makes it possible to stop at any desired height.

Every care has been taken in the construction of the mast climbing work platform to ensure that all safety aspects have been considered.

Depending on the application area, a choice can be made from different platform lengths, platform widths and permissible loading.

This instruction manual describes only the basic machine, in the standard form supplied by HEK Manufacturing BV.

**Read this instruction manual carefully before using the mast climbing work platform. Take all the safety precautions as described in chapter 3 into account.**



**CONTENTS**

FOREWORD	V	6. ASSEMBLY AND ANCHORING	6-1
CONTENTS	VI	6.1 Preparation for assembly	6-2
SURVEY OF ILLUSTRATIONS	VII	6.2 Ground support	6-3
EC DECLARATION OF CONFORMITY	VIII	6.3 Positioning the mast climbing work platform	6-4
MEANING OF THE SYMBOLS USED	X	6.3.1 Mast climbing work platform with single mast on a chassis	6-5
		6.3.2 Mast climbing work platform with one mast on a ground frame	6-6
1. TECHNICAL DETAILS	1-1	6.3.3 Mast climbing work platform with two masts on a chassis	6-8
1.1 General	1-1	6.3.4 Mast climbing work platform with two masts on ground frames	6-11
1.2 Electrical installation	1-5	6.4 Assembly of the mast	6-14
1.3 Drive unit	1-5	6.5 Anchoring the mast	6-17
1.4 Chassis	1-7	6.6 Adjusting the platform width	6-19
1.5 Ground frame	1-7	6.7 Setting the machine left or right	6-21
1.6 Platform construction	1-8	6.8 Checking and adjusting the lower striker plates	6-22
1.6.1 Symmetrical platform construction	1-8	6.9 Checking the autolevel switches	6-23
1.7 Loading of the mast climbing work platform	1-10	6.10 Adjusting the EMOS system	6-24
1.7.1 Outriggers chassis	1-10	6.11 Lightning protection	6-24
1.7.2 Single mast machine	1-11		
1.7.3 Twin mast machine	1-12	7. OPERATION	7-1
1.8 Anchorforces	1-14	7.1 General	7-1
		7.2 Preparation	7-1
2. COMPONENT DESCRIPTION	2-1	7.3 Testing	7-3
2.1 General description	2-1	7.4 Brake test	7-3
		7.5 Operation from the platform	7-4
3. SAFETY	3-1	7.6 Operation in an emergency situation	7-4
3.1 General	3-1	7.7 Eccentric overload device	7-6
3.2 Safety prior to use	3-1		
3.3 Safety in use	3-1	8. DISASSEMBLY AND TRANSPORT	8-1
3.4 Safety after use	3-3		
3.5 Built-in and additional safety features	3-3	9. MAINTENANCE	9-1
		9.1 General	9-1
4. TRANSPORT	4-1	9.2 Maintenance intervals	9-1
4.1 Repositioning on the building site	4-2	9.3 Autolevel mechanism check	9-3
4.2 Chassis drive unit	4-3	9.4 The motor brake	9-3
4.3 Repositioning with a crane	4-4	9.4.1 Operation	9-4
		9.4.2 Maintenance	9-5
5. CONTROL COMPONENTS	5-1	10. MALFUNCTION ANALYSIS	10-1
5.1 Power supply socket for the drive unit	5-1		
5.2 Power supply socket for the chassis	5-1	11. MACHINE DISPOSAL	11-1
5.3 Platform control box	5-2		
		12. LIST OF KEYWORDS	12-1
		APPENDICES	1

## SURVEY OF ILLUSTRATIONS

Fig.1	Dimensions	X	Fig.6-33	Control buttons	6-15
Fig.1-1	Mast element	1-2	Fig.6-34	Proximity switch	6-15
Fig.1-2	Platform element	1-2	Fig.6-35	Red top mast element	6-16
Fig.1-3	Plug-in fence	1-2	Fig.6-36	Mast cover	6-16
Fig.1-4	End fence	1-2	Fig.6-37	Anchoring	6-19
Fig.1-5	Corner post	1-2	Fig.6-38	Outrigger platform extension	6-20
Fig.1-6	Drive unit	1-4	Fig.6-39	Anchor ramp	6-20
Fig.1-7	Chassis	1-6	Fig.6-40	Machine setting left	6-21
Fig.1-8	Ground frame	1-6	Fig.6-41	machine setting right	6-21
Fig.1-9	Outrigger locking	1-10	Fig.6-42	switch left/right setting	6-21
Fig.1-10	Anchor forces	1-14	Fig.6-43	Adjusting lower striker plate	6-22
Fig.2-1	Basic set MSHF chassis/ ground frame	2-1	Fig.6-44	Brake lever drive unit	6-23
Fig.4-1	Transport MSHF	4-1	Fig.6-45	Autolevel switches	6-23
Fig.4-2	Locking pin outrigger chassis	4-2	Fig.6.46	Adjusting EMOS	6-24
Fig.4-3	Brake lever chassis	4-2	Fig.6-47	Lightning protection	6-25
Fig.4-4	Switch box chassis	4-3	Fig.7-1	Main switch	7-2
Fig.4-5	Control box chassis	4-3	Fig.7-2	Emergency push-button	7-2
Fig.5-1	Power supply socket drive unit	5-1	Fig.7-3	Brake lever drive unit	7-3
Fig.5-2	Power supply socket chassis	5-1	Fig.7-4	Push-buttons control box	7-4
Fig.5-3	Control box	5-2	Fig.7-5	Drive unit brake release	7-5
Fig.6-1	Position machine	6-1	Fig.7-6	Signal light	7-6
Fig.6-2	Ground support chassis	6-3	Fig.8-1	Drive unit brake release	8-1
Fig.6-3	Ground support ground frame	6-3	Fig.8-2	Autolevel locking locking pin	8-2
Fig.6-4	Distance to the facade	6-4	Fig.8-3	Control cable dummy plug	8-2
Fig.6-5	Locking pin outrigger chassis	6-5	Fig.8-4	Securing outrigger	8-2
Fig.6-6	Autolevel locking pin	6-5	Fig.8-5	Bundle platform elements	8-3
Fig.6-7	Lower striker plate	6-5	Fig.8-6	Locking pin outrigger	8-3
Fig.6-8	Lower striker plate	6-6	Fig.9-1	Drive unit brake release	9-3
Fig.6-9	Step	6-6	Fig.9-2	Motorbrake	9-4
Fig.6-10	Fence	6-6	Fig.9-3	Motorbrake	9-5
Fig.6-11	Gate safety switch	6-6			
Fig.6-12	Step	6-7			
Fig.6-13	Autolevel locking pin	6-7			
Fig.6-14	Fence	6-7			
Fig.6-15	Gate safety switch	6-7			
Fig.6-16	Locking pin outrigger chassis	6-8			
Fig.6-17	Autolevel locking pin	6-8			
Fig.6-18	Lower striker plate	6-8			
Fig.6-19	Step	6-9			
Fig.6-20	Fence	6-9			
Fig.6-21	Gate safety switch	6-10			
Fig.6-22	Autolevel locking pin	6-10			
Fig.6-23	Control cable dummy plug	6-10			
Fig.6-24	Autolevel locking pin	6-11			
Fig.6-25	Lower striker plate	6-11			
Fig.6-26	Gate safety switch	6-12			
Fig.6-27	Step	6-12			
Fig.6-28	Fence	6-12			
Fig.6-29	Autolevel locking pin	6-13			
Fig.6-30	Control cable dummy plug	6-13			
Fig.6-31	Power supply	6-14			
Fig.6-32	Main switch	6-14			

---

# EC DECLARATION OF CONFORMITY

**EC declaration of conformity for machines**  
(pursuant to Annex IIa of the Machine Directives 89/392/EEC)

We, **HEK Manufacturing bv**  
**Westelbeersedijk 18**  
**5091 SM Middelbeers**  
**The Netherlands**

hereby declare that, on the basis of its design and construction, the mast climbing work platform named below and brought into circulation by us conform to the relevant basic safety and health requirements contained in the EC Machine Directives.

Changes made to the machine without our consent invalidate this declaration.

This declaration applies to the mast climbing work platform:

**HEK MSHF**

In accordance with: **EC Machine Directives 89/392/EG, Annex IV**

EC number: **08/205/A 16-4912B, 1-7-1996**

Certified by ('Notified Body'): **TÜV HANNOVER/SACHSEN ANHALT E.V.**  
**HANNOVER, GERMANY**

Date/Manufacturer's signature: **Middelbeers, the Netherlands,**  
**November 1st 1999**



Signatory: **P.M. Blom, deputy manager**

## MEANING OF THE SYMBOLS USED



WARNING  
Failing to (exactly) comply with the working or operating instructions may lead to serious injury, fatal accident, severe mechanical damage or operating losses.



During use, no person may stand **under** the machine.



Danger: High voltage.



Danger of falling objects.

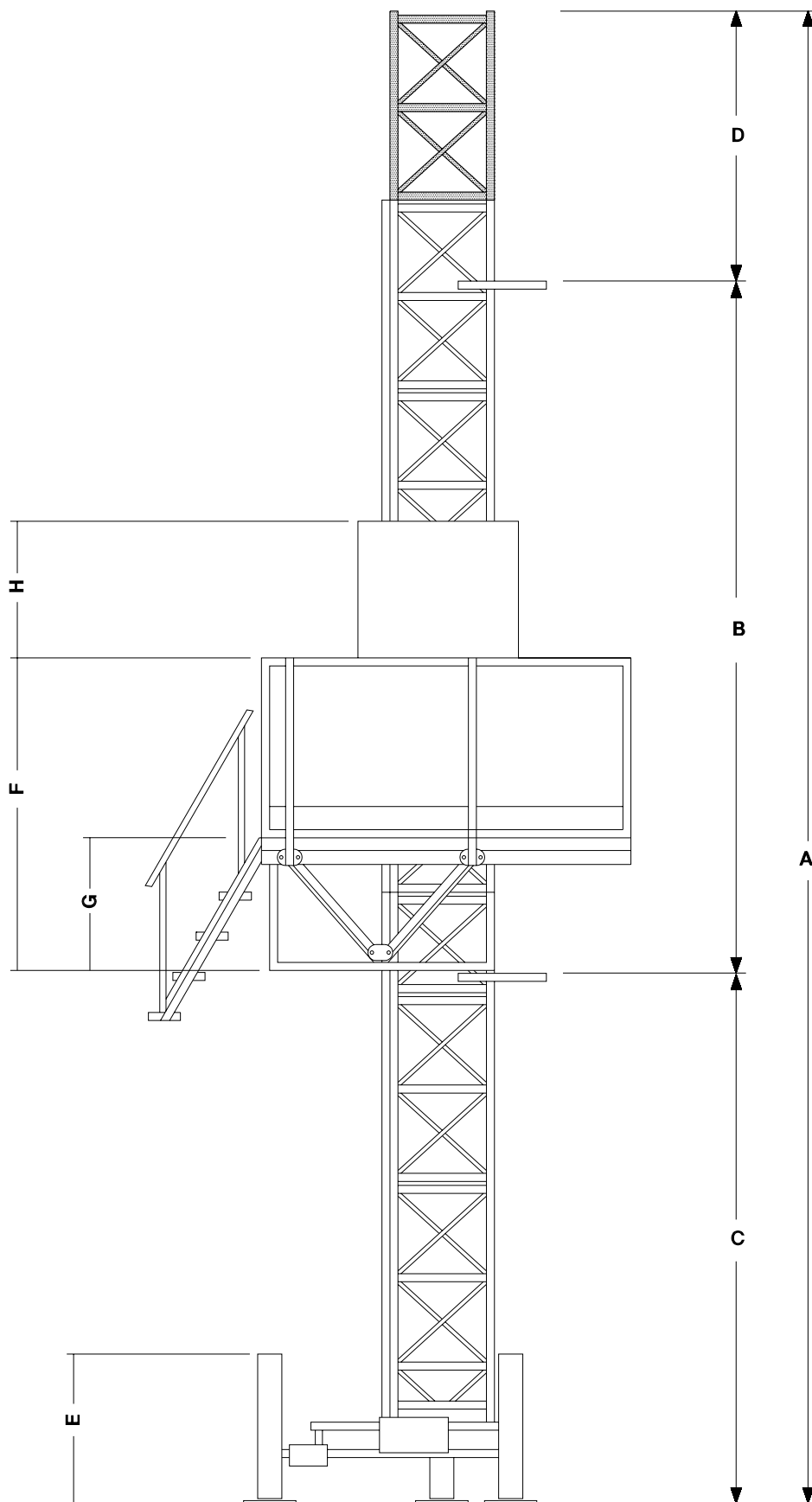

Fig.1 Dimensions

## 1. TECHNICAL DETAILS

### 1.1 General

Description	MSHF 1 mast		MSHF 2 masts	
Platform length	2.9 - 10.3 m	9.5 - 33.8 ft	8.5 - 23.5 m	27.9 - 77.1 ft
Platform width	1.5 - 2.5 m	4.9 - 8.2 ft	1.5 - 2.5 m	4.9 - 8.2 ft
Distance between mast centres	----	----	7.3 - 13.3 m	14.1 - 43.6 ft
Distance between anchors (B)	13 - 15 m	42.7 - 49.2 ft	13 - 15 m	42.7 - 49.2 ft
Max. mastheight free-standing (A)	20 m	65.6 ft	20 m	65.6 ft
Max. mastheight anchored (A)	150 m	492 ft	150 m	492 ft
Max. mastheight above last anchor (D)	8 m	26.2 ft	8 m	26.2 ft
Mast type	VRK700	VRK700	VRK700	VRK700
Max. number of persons	3	3	6	6
Platform speed	7 m/min	23 ft/min	7 m/min	23 ft/min
Loading capacity	see section 1.7	see section 1.7	see section 1.7	see section 1.7
Distance between cable guides	6 m	19.7 ft	6 m	19.7 ft
Height of first anchor for chassis (C)	15 m	49.2 ft	15 m	49.2 ft
Height of first anchor for ground frame (C)	3 m	9.8 ft	3 m	9.8 ft
Height of second anchor for ground frame	9 m	29.5 ft	9 m	29.5 ft
Height jacks chassis min - max (E)	0.67 - 0.97 m	2.2 - 3.0 ft	0.67 - 0.97 m	2.2 - 3.0 ft
Height platform incl. fence 1.1 m / 3.6 ft (F)	1.95 m	6.4 ft	1.95 m	6.4 ft
Height platform to deck (G)	0.83 m	2.7 ft	0.83 m	2.7 ft
Height fence 1.1 m / 3.6 ft to upper side mast cover (H)	1.36 m	4.5 ft	1.36 m	4.5 ft

**Note:**

The details are based on standard applications. In special situations, it may be possible to deviate from these. This may only be done with the prior written approval of the supplier.

For accessories and options see the accessory book.

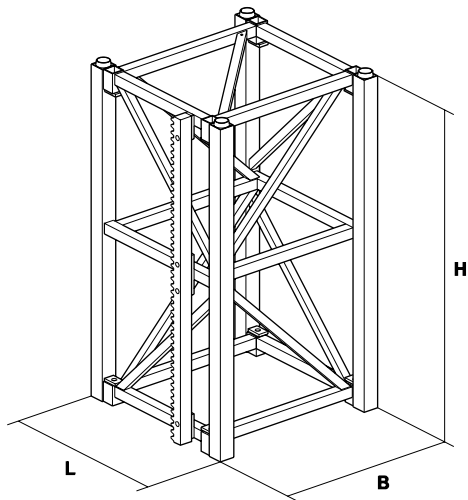

Fig.1-1 Mast element

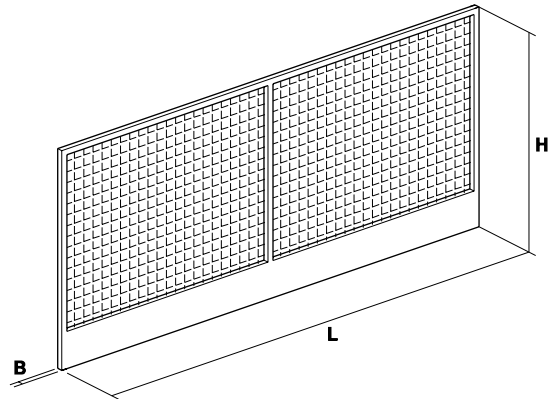

Fig.1-4 End fence

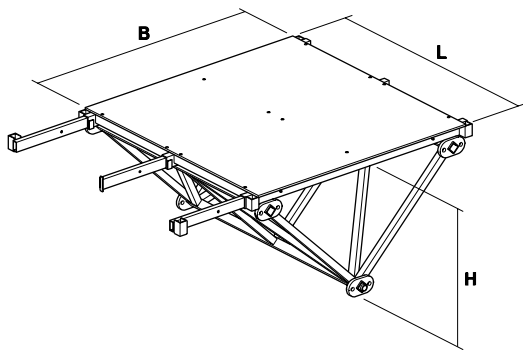

Fig.1-2 Platform element

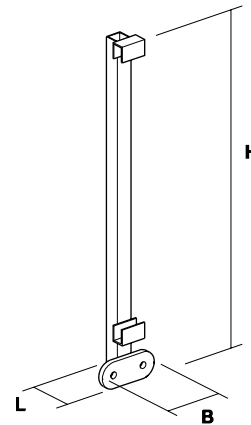

Fig.1-5 Corner post

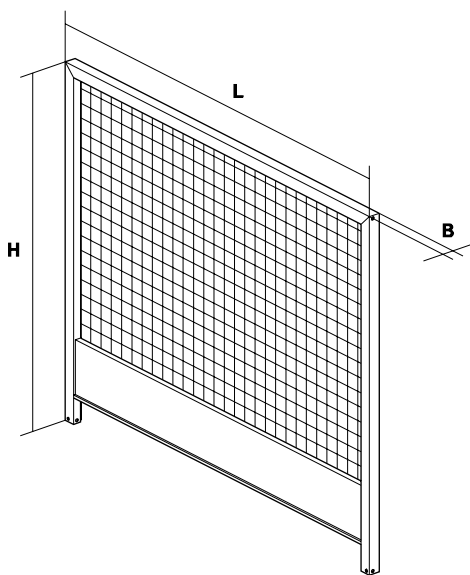

Fig.1-3 Plug-in fence

Part	l x b x h [mm]	weight [kg]	No. of bolts	bolt dim. & quality	torque [Nm]	other
Mast element 125	700x700x1256	80	4	M20 x 200 qual. 8.8	200	Module 8
Mast element 150	700x700x1508	103	4	M20 x 200 qual. 8.8	200	Module 8
Platform element 80	800x1580x800	90	6	M20 x 90 qual. 8.8	200	Max. platform extension façade side 1000 mm
Platform element 150	1500x1580x800	140	6	M20 x 90 qual. 8.8	200	Max. platform extension façade side 1000 mm
Plug-in fence 80	780x40x1120	12	---	---	---	---
Plug-in fence 150	1480x40x1120	18	---	---	---	---
End fence	2500x30x1120	30	---	---	---	---
Corner post	170x60x1300	6,5	---	---	---	---

Part	l x b x h [in]	weight [lb]	No. of bolts	bolt dim. & quality	torque [lb ft]	other
Mast element 125	27.6x27.6x49.4	176	4	M20 x 7.9 in qual. 8.8	150	Module 8
Mast element 150	27.6x27.6x59.4	227	4	M20 x 7.9 in qual. 8.8	150	Module 8
Platform element 80	31.5x62.2x31.5	198	6	M20 x 3.5 in qual. 8.8	150	Max. platform extension façade side 39.4 in.
Platform element 150	59.1x62.2x31.5	308	6	M20 x 3.5 in qual. 8.8	150	Max platform extension façade side 39.4 in
Plug-in fence 80	30.7x1.6x44.1	26	---	---	---	---
Plug-in fence 150	58.3x1.6x44.1	40	---	---	---	---
End fence	98.4x1.2x44.1	66	---	---	---	---
Corner post	6.7x2.4x51.2	14	---	---	---	---

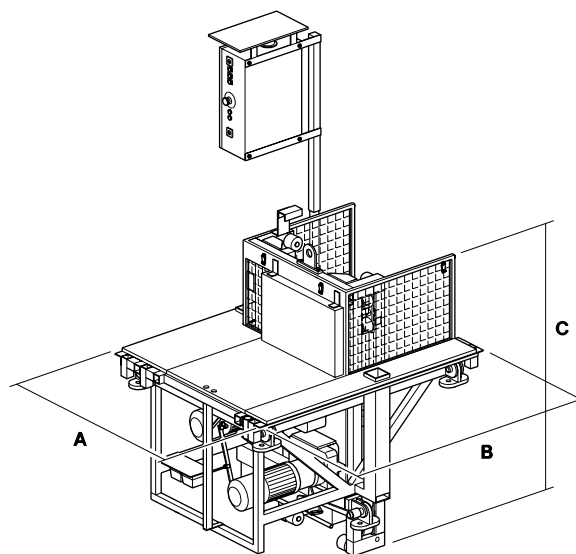

Fig.1-6 Drive unit

## 1.2 Electrical installation

		MSHF 1 mast	MSHF 2 masts
Number of motors		2	4
Rated power mast climbing work platform		2 x 2.1 kW	4 x 2.1 kW
Maximum starting current		± 80 A	± 160 A
Power consumption (based on S3-25%)		2 x 2.9 kVA	4 x 2.9 kVA
Supply voltage		200 - 240 V	
Minimum supply voltage		180V	
Phases		3 + Pe	
Supply frequency		50 or 60 Hz	
Fuse at building site (slow)		25 A	40 A
Control voltage		42 Vac	
Control voltage frequency		50/60 Hz	
Power supply (to machine)	up to 60 m / 197 ft	5 x 6 mm <sup>2</sup> / 5 x 0.0093 in	5 x 10 mm <sup>2</sup> 5 x 0.016 in
	up to 100 m / 328 ft	5 x 10 mm <sup>2</sup> / 5 x 0.016 in	
	up to 150 m / 492 ft	5 x 16 mm <sup>2</sup> / 5 x 0.025 in	5 x 16 mm <sup>2</sup> / 5 x 0.025 in
Machine cable / weight	5 x 6 mm <sup>2</sup> , 0.64 kg/m 5 x 0.0093 in / 0.32 lb/ft	up to 70 m / 230 ft	up to 40 m / 131 ft
	5 x 10 mm <sup>2</sup> , 1.11 kg/m 5 x 0.016 in / 0.43 lb/ft	up to 100 m / 328 ft	up to 75 m / 246 ft
	5 x 16 mm <sup>2</sup> , 1.80 kg/m 5 x 0.025 in / 0.74 lb/ft	up to 150 m / 492 ft	up to 150 m / 492 ft
Single phase outlet		120 V / 16 A	

## 1.3 Drive unit

Dimension A	1270 mm	50.1 in
Dimension B	1580 mm	62.2 in
Dimension C	1610 mm	63.4 in
Weight	950 kg	2090 lb

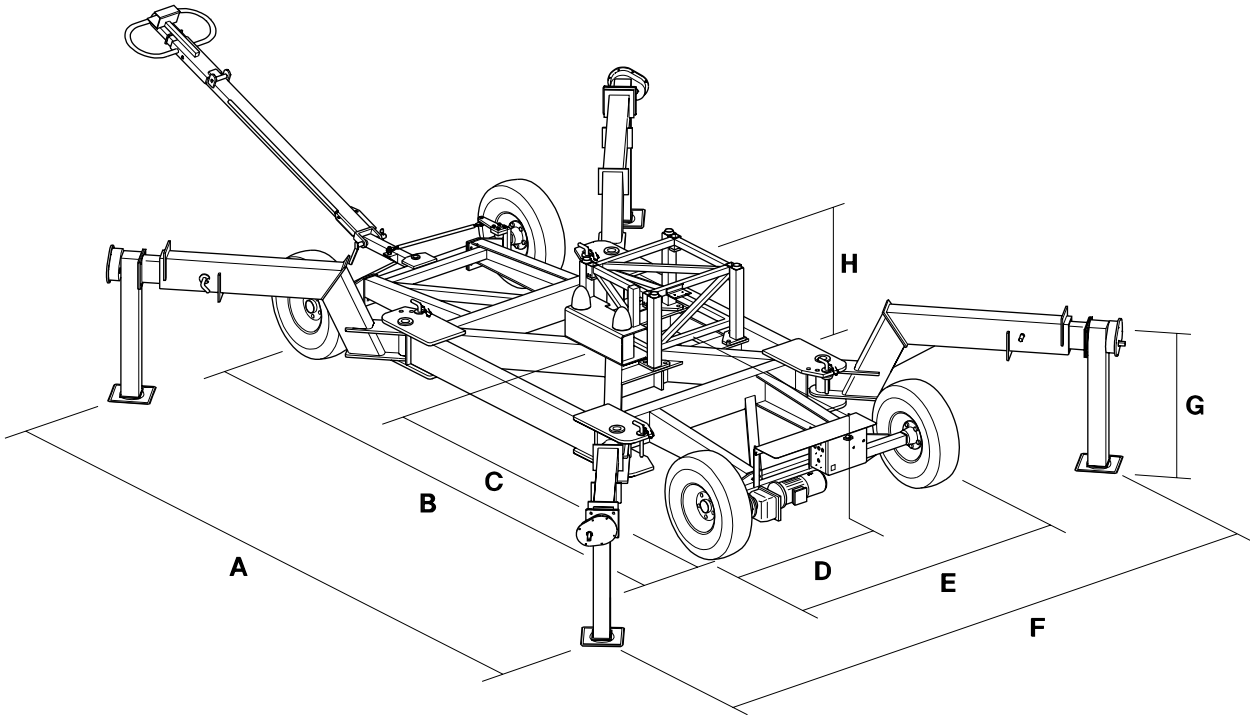

Fig.1-7 Chassis

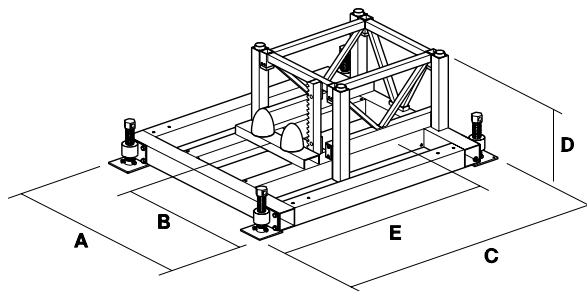

Fig.1-8 Ground frame

## 1.4 Chassis

Dimension A	4520 - 6540 mm	175.9 - 257.5 in
Dimension B	4300 mm	167.3 in
Dimension C	2150 mm	83.7 in
Dimension D	1250 mm	48.6 in
Dimension E	1770 mm	69.7 in
Dimension F	1600 - 4590 mm	63.0 - 178.6 in
Dimension G	668 - 968 mm	26.0 - 37.7 in
Dimension H	775 - 848 mm	30.2 - 33.0 in
Weight	1750 kg	3850 lb
Number of motors	1	1
Rated power	0.75 kW	0.75 kW
Tyre pressure	5 bar	71.5 psi
Driving speed	2 km/h	1.25 mph
Height of the platform from the ground	depending on lower striker plate	depending on lower striker plate

## 1.5 Ground frame

Dimension A	1200 mm	47.2 in
Dimension B	600 mm	23.3 in
Dimension C	1560 mm	61.4 in
Dimension D	500 - 600 mm	19.7 - 23.6 in
Dimension E	1100 mm	43.3 in
Weight	182 kg	400 lb
Height of the platform from the ground	depending of lower striker plate	depending of lower striker plate



**1.6 Platform construction**

**1.6.1 Symmetrical platform construction**

Drive unit: 1.30 m / 4.26 ft = A  
 Element 80: 0.80 m / 2.62 ft = B  
 Element 150: 1.50 m / 4.92 ft = C

A-symmetrical configurations may be possible. This may only be done with prior written approval of the supplier.

Single mast machine

							Length platform	
		B	A	B			2.9 m	9.5 ft
		C	A	C			4.3 m	14.1 ft
	B	C	A	C	B		5.9 m	19.4 ft
	C	C	A	C	C		7.3 m	24.0 ft
B	C	C	A	C	C	B	8.9 m	29.2 ft
C	C	C	A	C	C	C	10.3 m	33.8 ft

Twin mast machine

Mast distance*		Centre panel between the masts										Length platform	
7.3 m	24.0 ft	A	C	C	C	C	A					8.5 m	27.9 ft
8.1 m	26.6 ft	A	C	C	C	C	B	A				9.3 m	30.5 ft
8.8 m	28.9 ft	A	C	C	C	C	C	A				10.0 m	32.8 ft
9.6 m	31.5 ft	A	C	C	C	C	C	B	A			10.8 m	35.4 ft
10.3 m	33.8 ft	A	C	C	C	C	C	C	A			11.5 m	37.7 ft
11.1 m	36.4 ft	A	C	C	C	C	C	C	B	A		12.3 m	40.4 ft
11.8 m	38.7 ft	A	C	C	C	C	C	C	C	A		13.0 m	42.7 ft
12.6 m	41.3 ft	A	C	C	C	C	C	C	C	B	A	13.8 m	45.3 ft
13.3 m	43.6 ft	A	C	C	C	C	C	C	C	C	A	14.5 m	47.6 ft

Side panels (2x) in case of a symmetrical installation.  
 With multiple elements, the element of 1.5 m / 4.92 in (C) must be attached on the side of the mast.

Mast distance *	B	C	B + C	C + C	B + C + C	C + C + C
7.3 m	10.1 m	11.5 m	13.1 m	14.4 m	**	**
8.1 m	10.9 m	12.3 m	13.9 m	15.3 m	**	**
8.8 m	11.6 m	13.0 m	14.6 m	16.1 m	17.6 m	**
9.6 m	12.4 m	13.8 m	15.4 m	16.8 m	18.4 m	19.8 m
10.3 m	13.1 m	14.4 m	16.1 m	17.5 m	19.1 m	20.5 m
11.1 m	13.9 m	15.3 m	16.9 m	18.3 m	19.9 m	21.3 m
11.8 m	14.6 m	16.0 m	17.6 m	19.0 m	20.6 m	22.1 m
12.6 m	15.4 m	16.8 m	18.4 m	19.8 m	21.4 m	22.8 m
13.3 m	16.1 m	17.5 m	19.1 m	20.5 m	22.1 m	23.5 m

Mast distance*	B	C	B + C	C + C	B + C + C	C + C + C
24.0 ft	33.1 ft	37.7 ft	43.0 ft	47.2 ft	**	**
26.6 ft	35.8 ft	40.4 ft	45.6 ft	50.2 ft	**	**
28.9 ft	38.1 ft	42.7 ft	47.9 ft	52.8 ft	57.7 ft	**
31.5 ft	40.7 ft	45.3 ft	50.5 ft	55.1 ft	60.4 ft	65.0 ft
33.8 ft	43.0 ft	47.2 ft	52.8 ft	57.4 ft	62.7 ft	67.3 ft
36.4 ft	45.6 ft	50.2 ft	55.4 ft	60.0 ft	65.3 ft	70.0 ft
38.7 ft	47.9 ft	52.5 ft	57.7 ft	62.3 ft	67.6 ft	72.5 ft
41.3 ft	50.5 ft	55.1 ft	60.4 ft	65.0 ft	70.2 ft	74.8 ft
43.6 ft	52.8 ft	57.4 ft	62.7 ft	67.3 ft	72.5 ft	77.1 ft

\* The mast distance and thus the platform length can be enlarged (10cm / 3.94 in), by replacing one element 150 by two elements 80.

\*\* These combinations are not allowed.

## 1.7 Loading of the mast climbing work platform

### 1.7.1 Outriggers chassis

The outriggers of the chassis can be placed and locked in different positions. The maximum free standing height of the mast climbing work platform is also depended on the position of the outriggers.

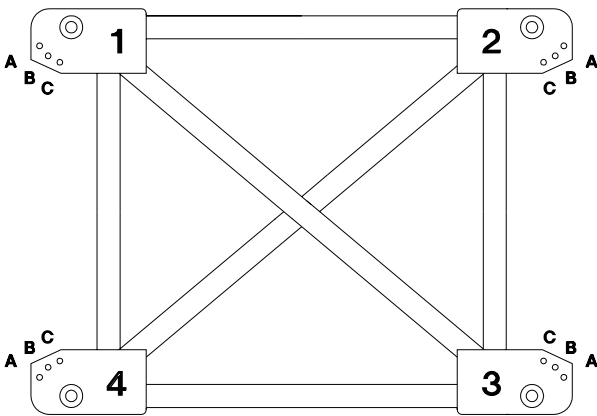
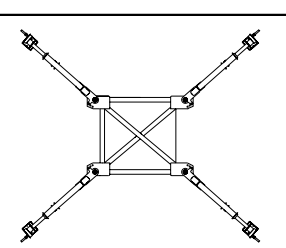
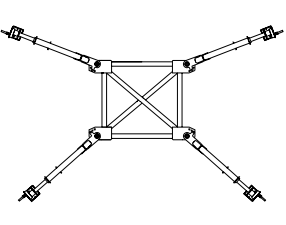
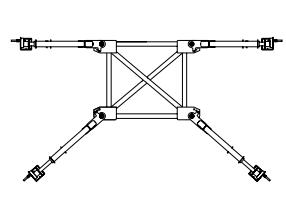

Fig.1-9 Outrigger locking

Position of the outriggers		Position of the locking pin				Maximum freestanding mast height	
		1	2	3	4		
	X -position front	A	A	A	A	20 m	65.6 ft
	X -position back	A	A	A	A	20 m	65.6 ft
	½K -position front	A	A	B	B	15 m	49.2 ft
	½K -position back	B	B	A	A	15 m	49.2 ft
	K -position front	A	A	C	C	7.5 m	24.6 ft
	K -position back	C	C	A	A	7.5 m	24.6 ft

### 1.7.2 Single mast machine



The payload must be equal distributed on the platform.

Drive unit: 1.30 m / 4.26 ft = A  
 Element 80: 0.80 m / 2.62 ft = B  
 Element 150: 1.50 m / 4.92 ft = C

The P numbers in the diagram are the EMOS program numbers. For adjusting the EMOS system see chapter 6.10.

#### Maximum payload single mast climbing work platform

Machine configuration							Maximum loading capacity depending of situation in use					
							Anchored			Free standing		
		B	A	B			2300 kg	5060 lb	P22	2300 kg	5060 lb	P22
		C	A	C			2200 kg	4840 lb	P22	2200 kg	4840 lb	P22
	B	C	A	C	B		2000 kg	4400 lb	P22	2000 kg	4400 lb	P22
	C	C	A	C	C		1800 kg	3960 lb	P22	1800 kg	3960 lb	P22
B	C	C	A	C	C	B	1600 kg	3520 lb	P22	1000 kg*	2200 lb*	P15*
C	C	C	A	C	C	C	1500 kg	3300 lb	P22	750 kg*	1650 lb*	P13*

\* If the maximum height is limited to 17.5 m / 57.4 ft, the payload and the EMOS setting of the anchored situation can be used.

**1.7.3 Twin mast machine**



The payload must be equal distributed on the platform.

Drive unit: 1.30 m / 4.26 ft = A  
 Element 80: 0.80 m / 2.62 ft = B  
 Element 150: 1.50 m / 4.92 ft = C

The P numbers in the diagrams are the EMOS program numbers. For adjusting the EMOS system see chapter 6.10.

Maximum payload twin mast climbing work platform (free-standing or anchored).

Mast distance		Centre panel between the masts										Max. payload		EMOS
7.3 m	24.0 ft	A	C	C	C	C	A					3500 kg	7700 lb	P15
8.1 m	26.6 ft	A	C	C	C	C	B	A				3500 kg	7700 lb	P15
8.8 m	28.9 ft	A	C	C	C	C	C	A				3500 kg	7700 lb	P15
9.6 m	31.5 ft	A	C	C	C	C	C	B	A			3500 kg	7700 lb	P16
10.3 m	33.8 ft	A	C	C	C	C	C	C	A			3500 kg	7700 lb	P16
11.1 m	36.4 ft	A	C	C	C	C	C	C	B	A		3000 kg	6600 lb	P14
11.8 m	38.7 ft	A	C	C	C	C	C	C	C	A		2700 kg	5940 lb	P14
12.6 m	41.3 ft	A	C	C	C	C	C	C	C	B	A	2300 kg	5060 lb	P12
13.3 m	43.6 ft	A	C	C	C	C	C	C	C	C	A	2000 kg	4400 lb	P11

Maximum payload twin mast climbing work platform with side panels (free-standing or anchored).

Mast distance [m]	Platform elements on the side of the mast					
	B	C	B + C	C + C	B + C + C *	C + C + C *
7.3	4000 kg / P19	4000 kg / P20	3800 kg / P20	3600 kg / P21	**	**
8.1	4000 kg / P20	3900 kg / P20	3700 kg / P20	3500 kg / P20	**	**
8.8	4000 kg / P21	3800 kg / P20	3600 kg / P20	3400 kg / P20	3200 kg / P20	**
9.6	3900 kg / P21	3700 kg / P21	3500 kg / P21	3300 kg / P21	3100 kg / P21	3000 kg / P21
10.3	3800 kg / P21	3600 kg / P21	3400 kg / P21	3300 kg / P21	3100 kg / P21	2900 kg / P21
11.1	3400 kg / P20	3500 kg / P21	3300 kg / P21	3200 kg / P21	3000 kg / P21	2800 kg / P21
11.8	3000 kg / P16	3300 kg / P19	3200 kg / P21	3100 kg / P21	2900 kg / P21	2700 kg / P20
12.6	2600 kg / P15	2800 kg / P16	3000 kg / P19	3000 kg / P21	2800 kg / P21	2600 kg / P21
13.3	2200 kg / P12	2400 kg / P15	2600 kg / P17	2700 kg / P19	2700 kg / P21	2500 kg / P20

Mast distance	Platform elements on the side of the mast					
	B	C	B + C	C + C	B + C + C *	C + C + C *
24.0 ft	8800 lb / P19	8800 lb / P20	8360 lb / P20	7920 lb / P21	**	**
26.6 ft	8800 lb / P20	8580 lb / P20	8140 lb / P20	7700 lb / P20	**	**
28.9 ft	8800 lb / P21	8360 lb / P20	7920 lb / P20	7480 lb / P20	7040 lb / P20	**
31.5 ft	8580 lb / P21	8140 lb / P21	7700 lb / P21	7260 lb / P21	6820 lb / P21	6600 lb / P21
33.8 ft	8360 lb / P21	7920 lb / P21	7480 lb / P21	7260 lb / P21	6820 lb / P21	6380 lb / P21
36.4 ft	7700 lb / P20	7700 lb / P21	7260 lb / P21	7040 lb / P21	6600 lb / P21	6160 lb / P21
38.7 ft	6600 lb / P16	7260 lb / P19	7040 lb / P21	6820 lb / P21	6380 lb / P21	5940 lb / P20
41.3 ft	5720 lb / P15	6160 lb / P16	6600 lb / P19	6600 lb / P21	6160 lb / P21	5720 lb / P21
43.6 ft	4820 lb / P12	5280 lb / P15	5720 lb / P17	5940 lb / P19	5940 lb / P21	5500 lb / P20

\* Maximum free standing height in X-position 15 meter.

\*\* These combinations are not allowed.

### 1.8 Anchorforces

Torque scaffold coupling: 50 Nm / 37 lb ft.

With the calculation of the anchor forces show in the table the following demands are considered:

- Anchor distance: 13-15 m / 42.6 - 49.2 ft
- Maximum mastheight above last anchor: 0.4 x anchor distance
- Loading during assembling:  
Single: max. 750 kg / 1650 lb  
+ 2 persons  
Twin: max. 1500 kg / 3300 lb  
+ 4 persons
- Maximum, windspeed during assembling: 6 Beaufort (12,5 m/sec). (41 ft/sec)
- Distance a (mast centre to facade): 0.9 -1.63 m / 35.4 - 64.2 in
- Distance b (between the anchor points on the facade): min. 0.7 m / 27.6 in
- Ratio a/b: 0.8 - 2.0

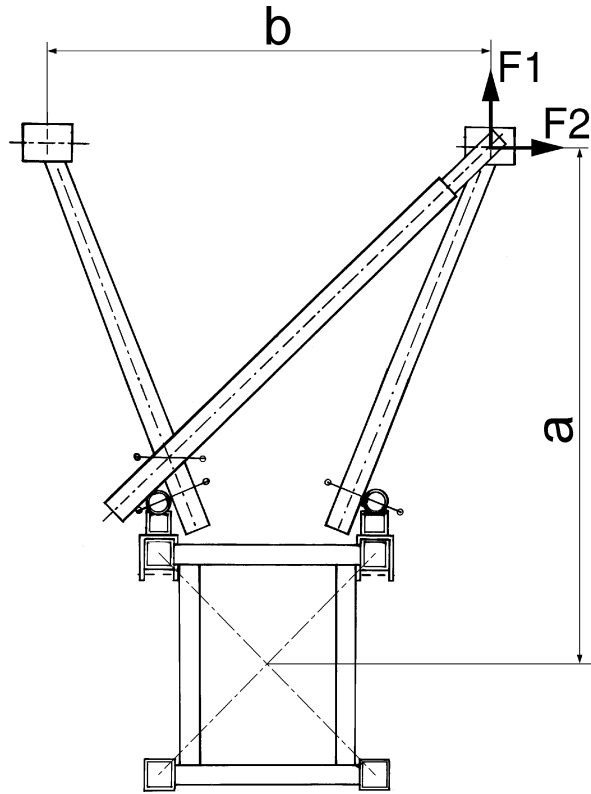

Fig.1-10 Anchor forces

The anchorforces of the MSHF up to 100 meters are given in the undermentioned table.

	Ratio a/b						
	0.8	1.0	1.2	1.4	1.6	1.8	2.0
Anchorforce F1	5.9 kN	7.0 kN	8.3 kN	9.5 kN	10.7 kN	11.9 kN	13.0 kN
	1327 lbf	1574 lbf	1865 lbf	2136 lbf	2406 lbf	2676 lbf	2923 lbf
Anchorforce F2	4.2 kN	4.7 kN	5.3 kN	5.7 kN	5.9 kN	5.6 kN	6.0 kN
	945 lbf	1057 lbf	1192 lbf	1281 lbf	1327 lbf	1259 lbf	1349 lbf

Above 100 meters the anchor forces will be 20 % higher than the anchor forces in the given table.

## 2. COMPONENT DESCRIPTION

### 2.1 General description

The basic set of the mast climbing work platform with rack and pinion drive consists of the following 5 main parts:

- \* drive unit
- \* mast
- \* platform elements and fences
- \* chassis or ground frame
- \* control system

The drive unit moves along the mast with the aid of Nylontron rollers.

The motors are fitted with centrifugal brakes which retard the platform if the speed of descent is exceeded.

The drive unit, operated by 2 electric motors, is moved along the mast by means of a single pinion on each motor. For a mast climbing work platform with two masts, the motors are automatically controlled to ensure parallel operation.

Much consideration has been given to simple and safe assembly and disassembly.

A crane on the platform (option) ensures that the mast elements can be positioned quickly and safely.

The platform can be adjusted to suit the required working situation with the use of separate platform elements. The width of the platform can be adjusted by means of outriggers.

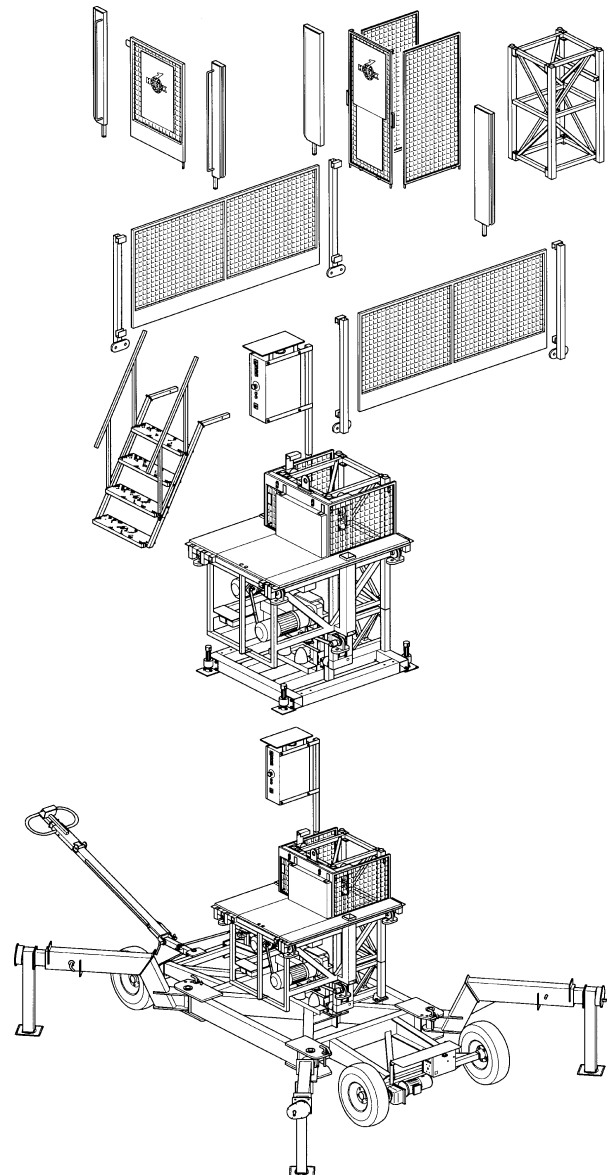

Fig.2-1 Basic set MSHF chassis/ground frame

All electrical connections, which must be disconnected for transport purposes, can be made by means of connectors.

The electrical installation is divided over three boxes:

- The control box on the platform.
- The connection box on the chassis (only when a chassis is used)
- The control box on the tow bar (only when a chassis is used)

The simple construction ensures that only a minimum of maintenance is required.

The most elements, the chassis, the drive unit, the cable guides and various other components are protected from corrosion by an appropriate surface treatment.

### 3. SAFETY



No changes or modifications may be made to the machine.



The ground surface must be sufficiently stable to support the weight of the machine and the mast.



The mast must ALWAYS be anchored in accordance with the instructions



If during assembly and disassembly, the fences do not provide sufficient protection, suitable safety harness must be used at heights above 2 metres.

- If the TOP limit switch fails and the red topmast is not mounted, so that the mast climbing work platform continuous to rise, the drive unit will rest on the safety hooks.
- If the pinion runs out the rack the EMOS system will stop the drive unit by means of differential current measurement.

#### 3.2 Safety prior to use

- The chassis or ground frame must be effectively supported.
- The working area around the machine must be free from obstacles.
- The machine must be securely anchored at the specified intervals.

#### 3.1 General

The machine is constructed to be safe, both during assembly and in use. The machine is thus provided with the following built-in and additional safety features:

- The motor brake works automatically if the supply voltage fails.
- If the TOP limit switch fails to operate, so that the mast climbing work platform continues to rise, an additional emergency TOP limit switch is operated.
- If the LOWER limit switch fails to operate, so that the mast climbing work platform continues to descend, an additional emergency LOWER limit switch is operated.

#### 3.3 Safety in use



In winds of strengths above 6 Beaufort (12.5 m/s) (41.1 ft/s) by a freestanding machine or 7 Beaufort (15.7 m/s) (51.5 ft/s) by an anchored machine, the machine must not be used and the platform must be set in the lowest position.



There must be no obstructions in the path of the machine.



During use, no person should stand **under** the machine.



Material must never extend beyond the outer limits of the platform. Items which may roll must be properly secured. Materials must never be stacked against the fencing.



If work must be carried on close to high voltage cables, a minimum safety distance of 15 m / 50 ft must be maintained.



When materials and/or tools with a large surface area will be used contact your supplier in connection with wind sensitivity.

- If the machine is to be used during the hours of darkness, the area must be adequately lit, so that the user has a good view in all conditions.
- In order to ensure that no person unintentionally walks under the platform, the mast climbing work platform must be surrounded with suitable fencing.
- The machine may only be used for the purpose for which it was designed, that is, the vertical transportation of persons and materials with a maximum weight within the design limits of the particular construction.
- Loads (materials, persons, etc.) must be distributed in accordance with the loading diagram.
- Operations on the mast climbing work platform may only be carried out by persons with adequate knowledge and qualifications to do so.
- Inspection and maintenance must be carried out as given in this instruction manual.
- During assembly and maintenance, the mast climbing work platform may not be used for other purposes.
- Keep hatches in the base of the platform clear. From the platform it must be possible to get, to the emergency descent controls via the hatches.
- The competence and sense of responsibility of the operator or engineer are essential to the efficient use of the platform.
- Local safety laws and regulations must always be followed.
- Technical personnel must be in a position to deal with any difficulty encountered in every possible situation during assembly and disassembly. The operating personnel must be familiar with those situations which can occur during use.
- If operating or technical personnel report errors or dangers or are not aware of the safety regulations, the owner or the person responsible must be informed immediately.
- For machines with two masts, there must always be two persons present on the platform during use. This in case the need to make an emergency descent.
- The working area must be kept free from obstacles (building materials, dirt, snow, etc.).
- Fences must never removed during normal use.
- The platform must only be entered and/or loaded when it is in its lowest position. The same rule applies to leaving the platform.
- When electrical storms are expected, work on the platform must be stopped in time to avoid the danger of lightning strikes. The power supply must be switched off and the connector withdrawn from the supply socket.

- Platform extensions on telescopic supports may only be used to carry personnel. Such personnel may only stand on these extensions when the machine is stationary.
- If erecting two adjacent platforms there must be a clear gap between the ends of the platforms of at least 0.5 meter / 19.7 inch.

### **3.4 Safety after use**

- Transport on public roads must only be done with a truck intended for the purpose.
- The platform must be placed in the lowest position and the main switch must be secured.

### **3.5 Built-in and additional safety features**

The MSHF mast climbing work platform is provided with the following in-built and additional safety features:

- Phase control relay in the control box.
- "Emergency stop" push button on every control box.
- Electrical access protection.
- Hooks on the drive unit. The platform remains secured on these should all the limit switches fail and should the red mast top section also be missing.
- Autolevel for machines with two masts. Locks the platform if one side drops more than the other during an emergency descent.
- In the event of a power failure the motor brakes are operated automatically to prevent the platform descending unexpectedly.

- Centrifugal brakes ensure a controlled descent in the event of an emergency.
- The single mast construction has an eccentric overload safety device. This locks the platform if the platform is overloaded on one side.
- The Emos system locks the platform if one of the motors fails.
- In the event of a power failure it is possible for the platform to make an emergency descent by manually releasing the motor brakes.
- Audio Visual Warning. During descent of the platform, a buzzer will sound and a light will flash underneath the platform.
- The mast climbing work platform can only be moved on the chassis when the platform is in the lowest position.



#### 4. TRANSPORT



Transportation on the chassis over the public roads is not permitted.



The national valid traffic regulations must be observed.

Because of its limited dimensions, the basic implementation of the machine can be transported with a normal lorry. Ensure that, during transport, all securing devices are properly fitted and that the machine is lowered onto the buffers.

Disassemble the machine before transporting it as described in chapter 8.

For the transport dimensions, see chapter 1.

For transport, all fences, steps and mast protection must be removed.

For transportation, secure the machine carefully onto the loading platform of the transport vehicle.

The machine can be loaded and unloaded from the transport vehicle using a crane mounted on the vehicle, a crane on the building site or a fork-lift truck. See figure 4-1 for loading and unloading points. Set the machine down carefully to avoid damage.

See figure 4-1

A Lifting point, for drive unit only!

B Support points for the fork of a fork-lift truck.

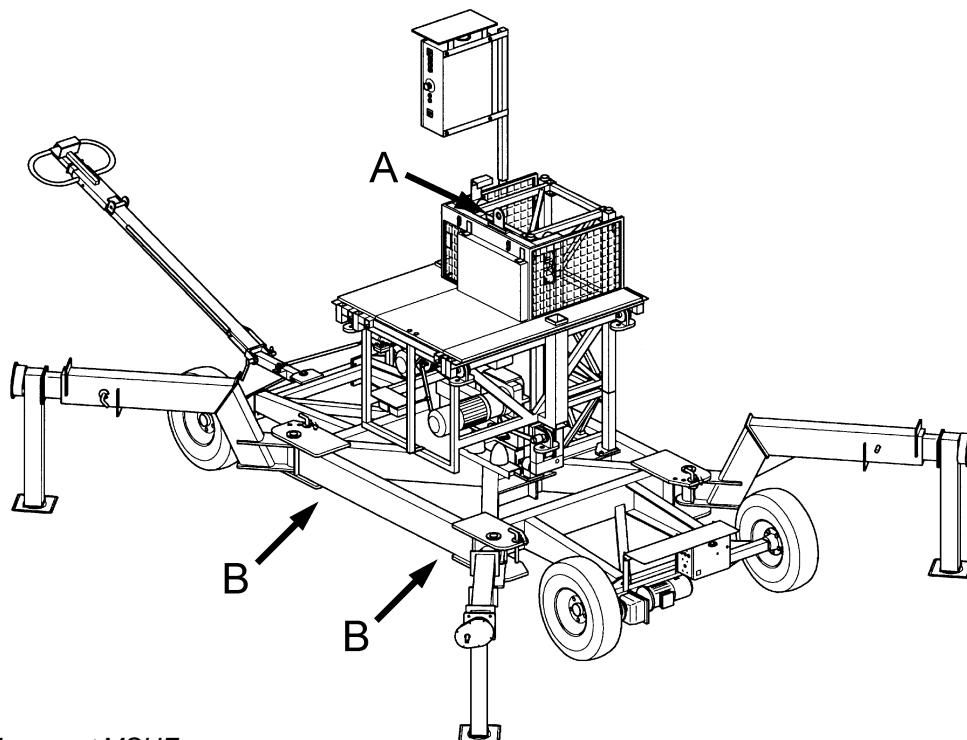

Fig.4-1 Transport MSHF

#### 4.1 Repositioning on the building site



Ensure that trees, power cables etc., cannot be touched.



During movement there may be no load on the platform.

Once on the building site, the mast climbing work platform can be moved in the lowest position on its chassis.

On a hard flat horizontal surface and when there is no wind, the mast may have a maximum height of 20 m / 65.6 ft during repositioning. The platform must be on the buffers. The legs must be set out in an X position and secured. The jack must be screwed out until they just are clear the ground.

When the circumstances are unfavourable than the above mentioned circumstances, contact your supplier.

A machine with two masts may only be repositioned on its chassis if no curves must be negotiated. If a curve must be followed, the machine must first be split into two single-mast machines. Take the maximum platform length of a single mast machine into account.

If there is no electrical power supply available, the chassis can be moved by hand or behind a vehicle. The hand brake lever on the chassis motor must then be used.

The maximum speed at which the chassis may be towed behind a vehicle is 30 m/min / 98.4 ft/min. Exceeding this speed can cause serious damage to the motor.

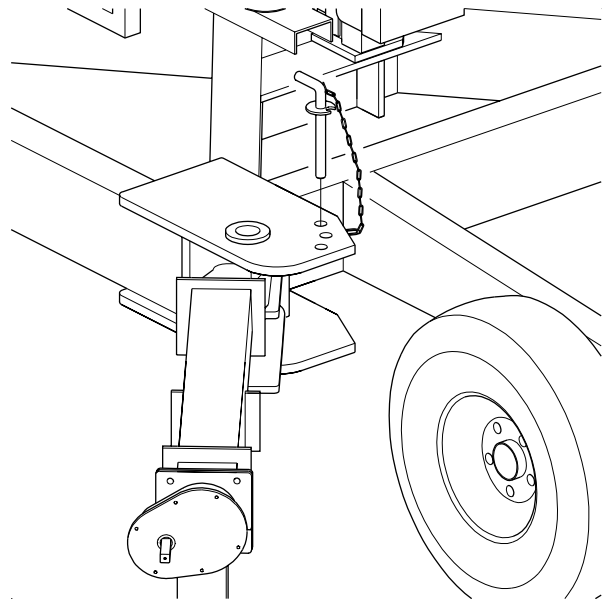

Fig.4-2 Locking pin outrigger chassis

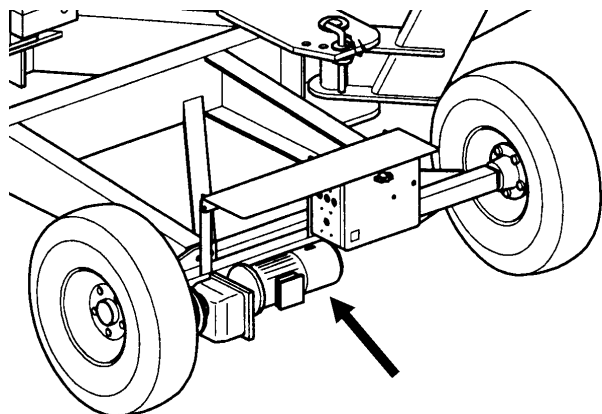

Fig.4-3 Brake lever chassis

## 4.2 Chassis drive unit



Moving the machine on its chassis over public roads is not permitted.



During movement there may be no load on the platform.

1. Place the platform in the lowest position.
2. Check that the tow bar is secured.
3. Insert the connector from the platform in the socket on the switch box of the chassis.
4. Connect the control cable from the tow bar to the chassis.
5. The chassis can be repositioned by pushing the knob (arrow) of the required direction. The control voltage can always be switched off by pushing the emergency push-button.

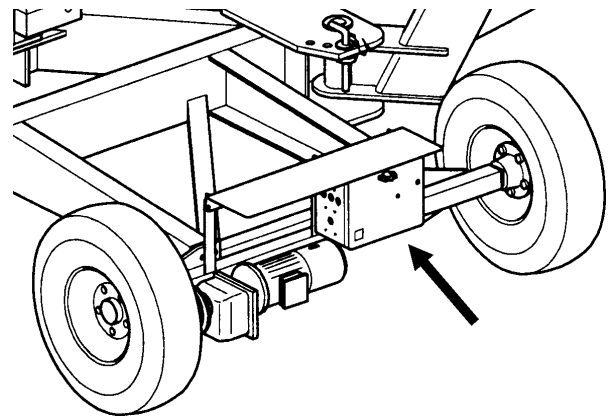

Fig.4-4 Switch box chassis

After the chassis has been repositioned, the red push-button must be pressed and the connectors for the power supply and controls withdrawn.

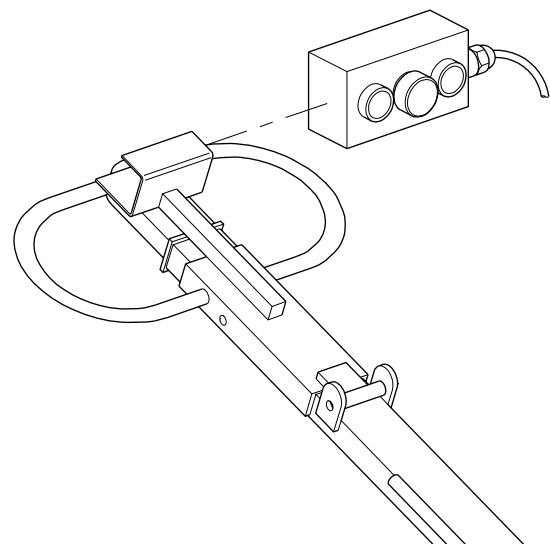

Fig.4-5 Control box chassis

### 4.3 Repositioning with a crane



During movement there may be no load on the platform.

At the building site the mast climbing work platform can be repositioned with a crane under the following circumstances.

A maximum of 9 mast elements may be mounted on the chassis or the ground frame. The eye hook of the crane can be attached to the mast with lifting slings.

The total transport weight can be calculated on the undermentioned way.

No. of drive units	x 950 kg / 2090 lb	=	
No. of chassis	x 1750 kg / 3850 lb	=	
No. of ground frames	x 182 kg / 400 lb	=	
No. of platform elements 80	x 90 kg / 198 lb	=	
No. of platform elements 150	x 140 kg / 308 lb	=	
No. of mast elements 125	x 80 kg / 176 lb	=	
No. of mast elements 150	x 103 kg / 227 lb	=	
No. of plug-in fences 80	x 12 kg / 26 lb	=	
No. of plug-in fences 150	x 18 kg / 40 lb	=	
No. of head fences	x 30 kg / 66 lb	=	
No. of corner posts	x 6,5 kg / 14 lb	=	
			_____ +
Total transport weight		=	kg / lb

## 5. CONTROL COMPONENTS

### 5.1 Power supply socket for the drive unit

The power supply cable for the electrical supply between the building site connection and the mast climbing work platform must be connected to the socket. See chapter 1 for the cable specifications.

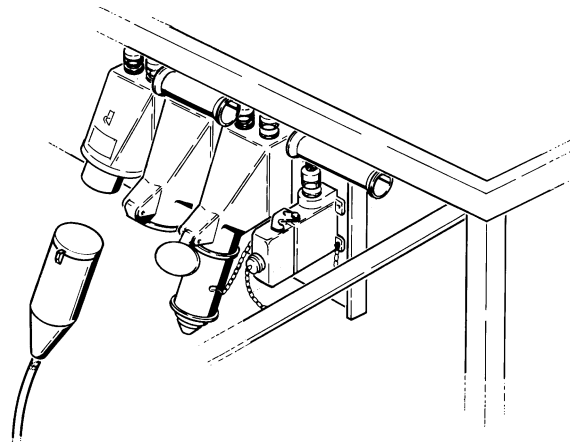

Fig.5-1 Power supply socket drive unit

### 5.2 Power supply socket for the chassis

The power supply cable for the electrical supply between the building site connection and the chassis must be connected to the socket.

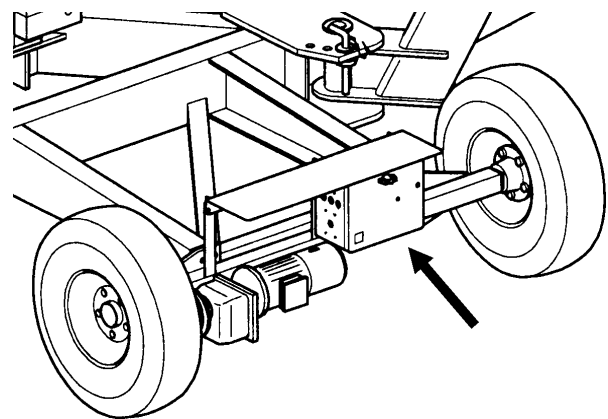

Fig.5-2 Power supply socket chassis

### 5.3 Platform control box

The door of the control box is secured with two quick-release fastener.

The control box is provided with the following push buttons:

1. Main switch.
2. Info panel.
3. Config panel.
4. Signal light.
5. Adjustment switch EMOS.
6. Push button UP.
7. Blue control light.
8. Push button DOWN.
9. Emergency push-button.
10. Keyswitch buffer.
11. Horn.
12. Keyswitch adjustment left/right.

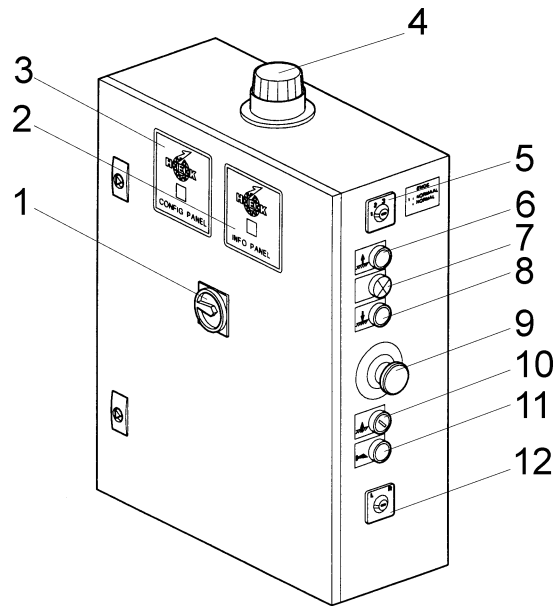

Fig.5-3 Control box

When the Emergency push-button is pressed it is locked in the depressed position. It can be unlocked by rotating it.

The main switch can be secured with a padlock to prevent unauthorized use of the platform.

The following components are mounted in the control box:

- the main switch
- the safety relay
- the control relay
- the transformer
- the automatic fuses

## 6. ASSEMBLY AND ANCHORING

Definition left and right in relation to positioning:

Left-hand: Viewed from the step side, the machine is fitted to the left-hand side.

Right-hand: Viewed from the step side, the machine is fitted to the right-hand side.

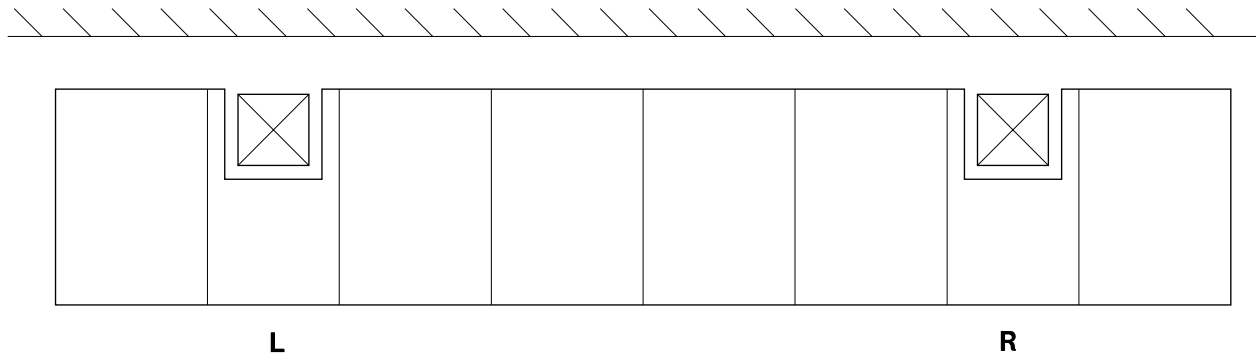

Fig.6-1 Position machine

If assembly work must be interrupted, this must be done in such a way that, when the work is restarted it is clear what stage had been reached when work was stopped. For this reason always complete a part of the assembly, for example, assemble collect or secure all the components for a connection, complete a ground support or completely assemble an anchor before stopping work.

While the mast is being erected, no more than two persons with a single mast machine or four persons with a twin mast machine, may be on the platform, so that no more than 75% of the lifting capacity is used.

The assembly must always be followed by a test run, as described in section 7.3. Until the test has been performed, the platform may not be used for any purpose other than transporting its own mast elements and anchoring components.

The loading of the mast climbing work platform must be planned so that when, in the assembly situation, the maximum height of the mast above the last anchor is reached (the maximum distance between anchors), the material load on the platform is a minimum.

## 6.1 Preparation for assembly



Ensure that the site where the mast climbing work platform will be assembled accords with the national requirements and that permission has been obtained from the relevant authorities for the assembly.

- Ensure that a suitable power supply, good lighting, lifting equipment and tools are available.
- Ensure that the building site is easily accessible to the vehicle which will deliver the mast climbing work platform.
- Prepare the site with suitable support and anchoring facilities.
- Ensure that the position where the mast climbing work platform will stand has good drainage.
- Plan the positioning of the mast climbing work platform so that where the mast needs to be anchored, it can be so anchored with the standard material.
- The components of the mast climbing work platform mast should be placed as close as possible to the place where it will be assembled.
- The electrical power supply connection must be placed as close to the mast climbing work platform as possible so as to reduce the voltage drop to a minimum. If the voltage reduction is too great the machine may not function correctly.

## 6.2 Ground support

Before the position for the mast climbing work platform is prepared a check must be made to ensure that the distance between the mast and the working surface can be spanned by the standard anchoring material.

1. Ensure that the forces are spread over as large an area as possible.
2. The soil must be able to withstand a ground pressure of at least  $2 \text{ kg/cm}^2 / 30 \text{ lb/in}^2$ . If this requirement is not met, soil improvement must be carried out such that the ground satisfies this minimum requirement.
3. The ground support must be flat and centrally loaded with a minimum ground support of  $400 \times 400 \text{ mm} / 15.7 \times 15.7 \text{ in}$ .

When a chassis is used, a ground support must be placed under the jack close to the mast and under the jack of the 4 extending legs. The frame must have a support placed under the mast and under the 4 corners (not under the jacks).

4. The ground support must be durable and of such a quality that the load can be transferred without plastic deformation.
5. If the machine is installed on a concrete foundation or on a hard road surface, the installation must be provided with wooden packing to prevent slipping.

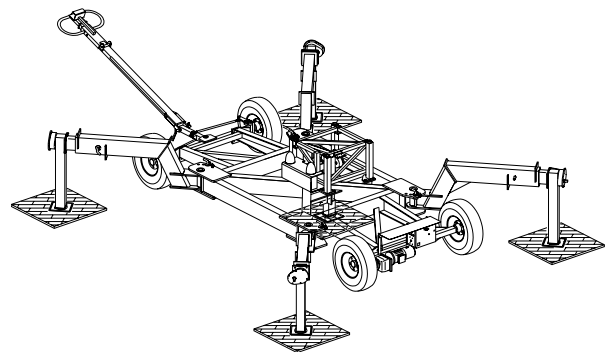

Fig.6-2 Ground support chassis

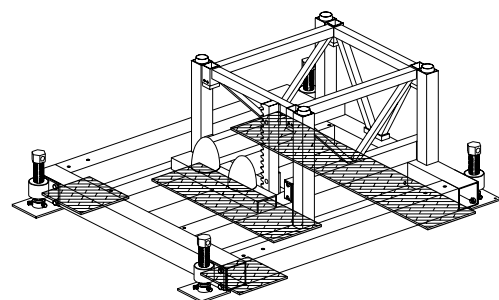

Fig.6-3 Ground support ground frame

### 6.3 Positioning the mast climbing work platform



A fence (height 1.10 m / 43.3 in) completely surrounding the platform is compulsory. If the distance between the platform and the facade is 0.3 m - 0.5 m / 11.8 in - 19.7 in a fence with a height of 0.7 m / 27.6 in can be used. If the distance between the platform and the facade is less than 0.3 m / 11.8 in a fence is not compulsory but in this case a kick board with an height of 0,15m / 5.9 in must be fitted.



Wheels of the chassis should not have a bearing function while assembly and operating the platform.

Distance to the facade with standard anchoring.

A = 575 - 1300 mm / 22.6 - 51.2 in

B = 550 - 1275 mm / 21.7 - 50.2 in

C = 25 mm / 1 in

There are four ways in which the mast climbing work platform can be placed:

- single mast, freestanding (chassis mounted)
- single mast, anchored (chassis or ground frame mounted)
- two masts, freestanding (chassis mounted)
- two masts, anchored (chassis or ground frame mounted).

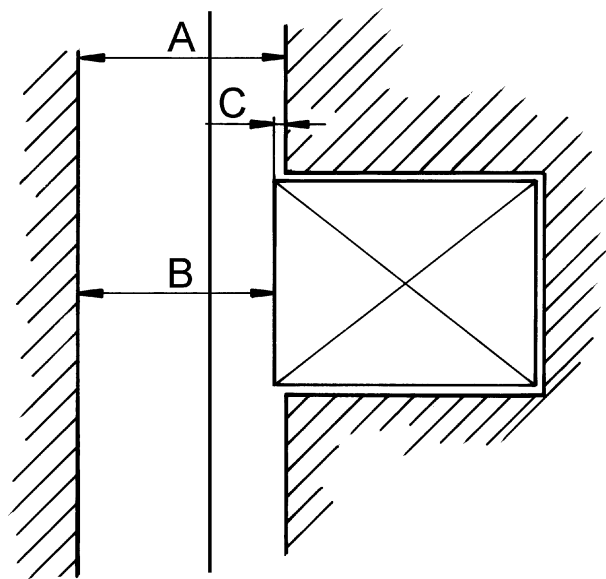

Fig.6-4 Distance to the facade

### 6.3.1 Mast climbing work platform with single mast on a chassis

1. Position the chassis parallel to the wall.
2. Withdraw the outriggers on the step side and secure them. Withdraw the outriggers on the side nearest the wall as far as possible. The maximum height for a freestanding machine depends on the position of the outriggers and the loading (see loading diagram, chapter 1.5).
3. Place the ground supports.
4. Unscrew the jack until the wheels no longer contact the ground and adjust the machine to be level. The measurement must be done with a spirit level with a minimum length of 1 meter / 40 inch.
5. Check that the locking pin for securing the autolevel device and the lower striker plate are mounted.
6. Assemble the platform components sequentially on both sides until the desired length is attained. The platform may not exceed the maximum length.
7. Tighten the platform bolts until the specified torque is applied.
8. The width of the platform can be adjusted to fit the form of the façade. See section 6.6.

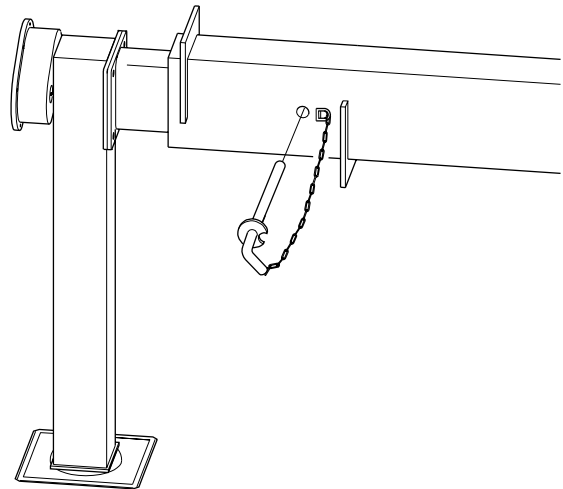

Fig.6-5 Locking pin outrigger chassis

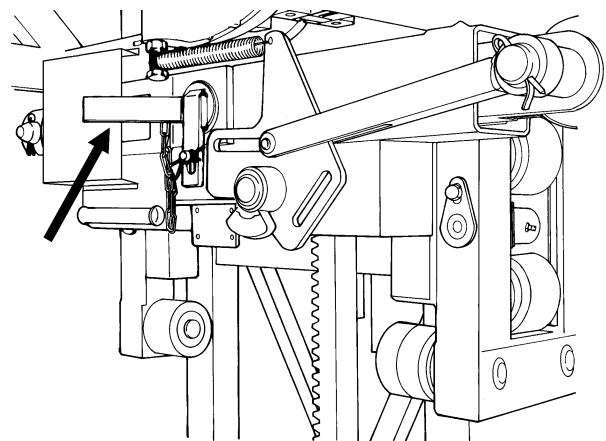

Fig.6-6 Autolevel locking pin

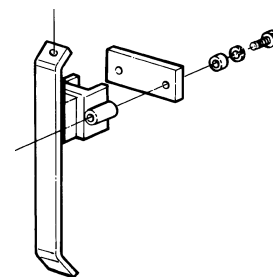

Fig.6-7 Lower striker plate

9. Mount the steps and secure them with locking pins.
10. Mount the fencing and secure it with "hairpins".
11. Mount the gate and the cam for the gate safety switch. The roller must fall into the cam when the gate is closed

**6.3.2 Mast climbing work platform with one mast on a ground frame**

1. Position the ground frame parallel to the wall.
2. Place the ground supports.
3. Level the machine using the jacks. Ensure that the mast is vertical in both directions by checking with a spirit level (with a length of at least 1 metre / 40 inch) placed against two adjacent sides of the mast. Place wooden packing under the machine to provide optimum load spreading and stability.

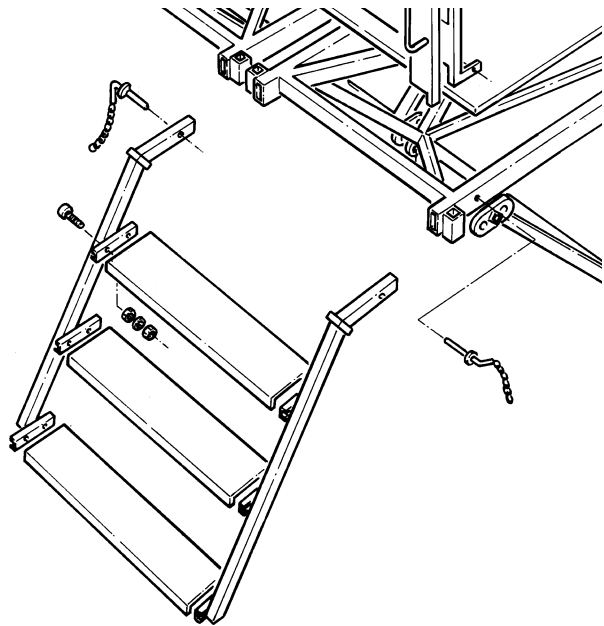

Fig.6-9 Step

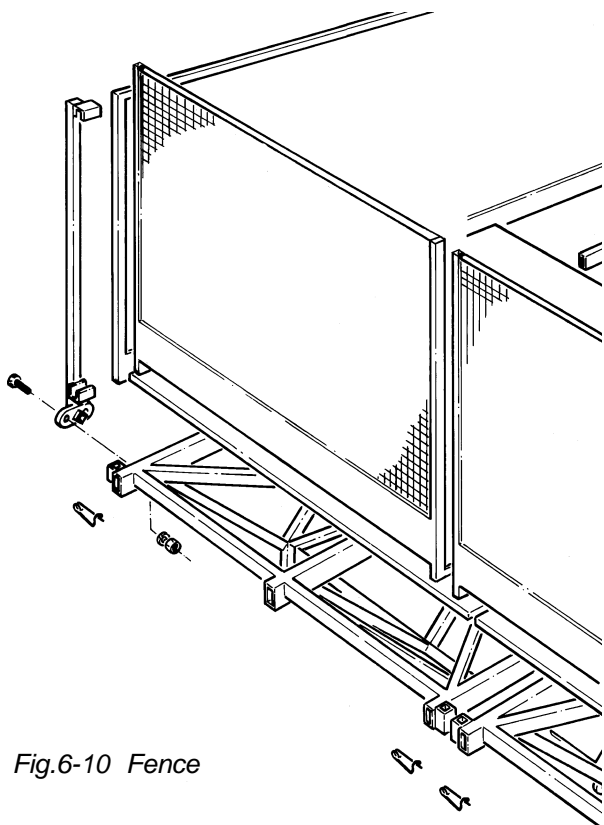

Fig.6-10 Fence

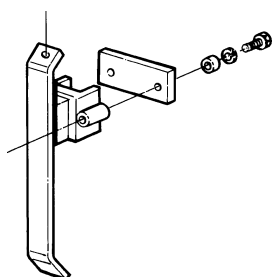

Fig.6-8 Lower striker plate

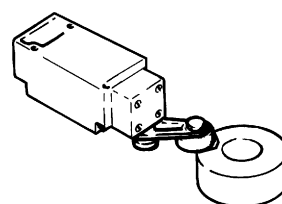

Fig.6-11 Gate safety switch

4. Check that the locking pin for securing the autolevel and the lower striker plate are mounted.
5. Assemble the platform components sequentially on both sides until the desired length is attained. The platform may not exceed the maximum length.
6. Tighten the platform bolts until the specified torque is applied.
7. The width of the platform can be adjusted to fit the form of the façade. See section 6.6.
8. Mount the steps and secure them with locking pins.
9. Mount the fencing and secure it with "hairpins".
10. Mount the gate and the cam for the gate safety switch. The roller must fall into the cam when the gate is closed.

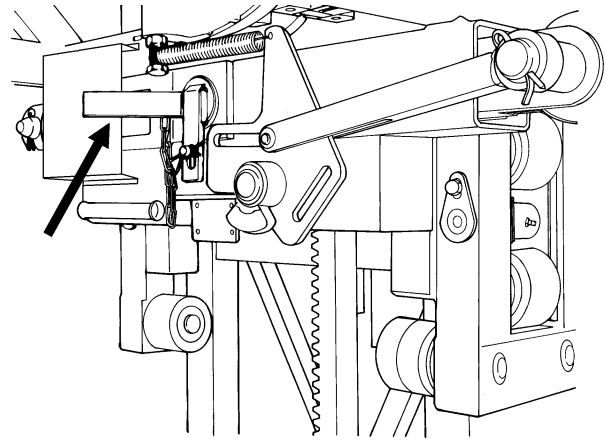

Fig.6-13 Autolevel locking pin

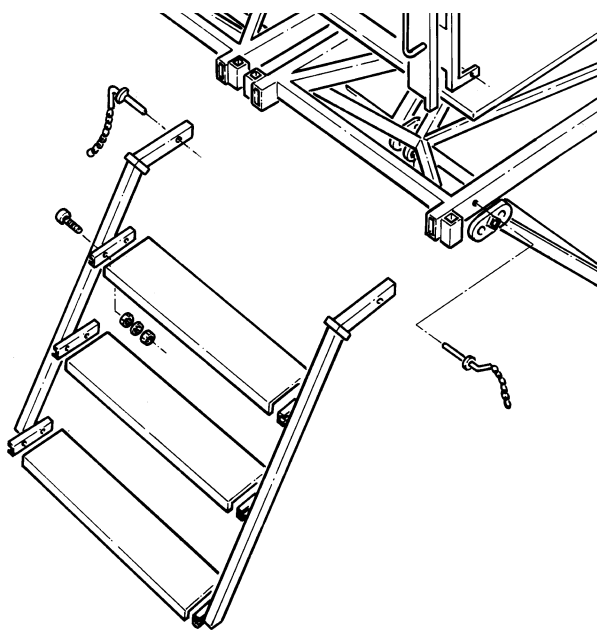

Fig.6-12 Step

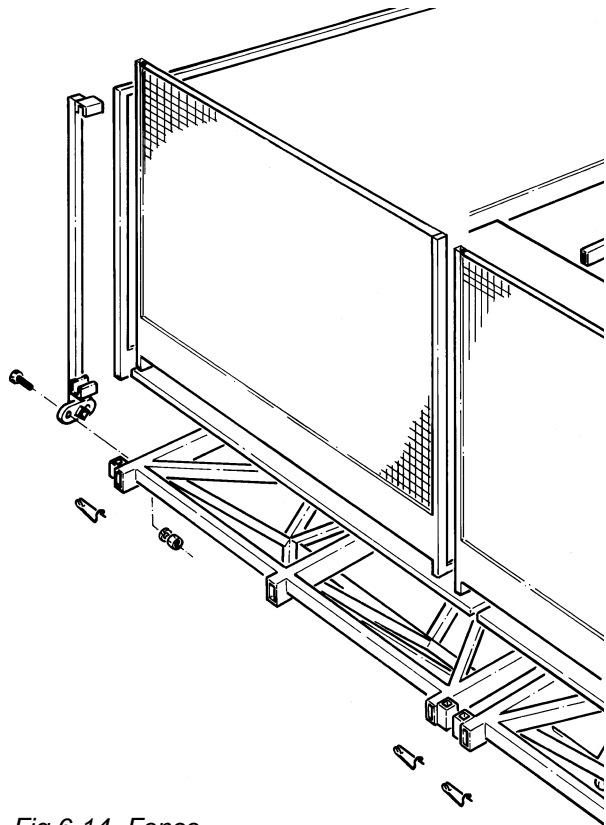

Fig.6-14 Fence

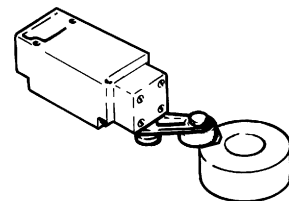

Fig.6-15 Gate safety switch

### 6.3.3 Mast climbing work platform with two masts on a chassis



One drive unit must be adjusted for "left" and the other for "right".

1. Check that the left-hand machine is adjusted for "left" and the right-hand machine for "right". See section 6.7.
2. Position the chassis parallel to the wall and with a separation to allow for the required distance between the masts + 1 metre / 3.3 ft.
3. Withdraw the outriggers on the step side completely and secure them. The outriggers on the side facing the wall should be withdrawn as far as possible.  
The maximum freestanding height depends on the position of the telescopic arms and the loading (See loading diagram, chapter 1.5).
4. Place the ground supports for this chassis.
5. Unscrew the jack for this chassis until the wheels no longer touch the ground and level the machine. The measurement must be done with a spirit level with a minimum length of 1 meter / 40 inch.
6. Check that the autolevel locking pins and the lower striker plates are mounted on both chassis.

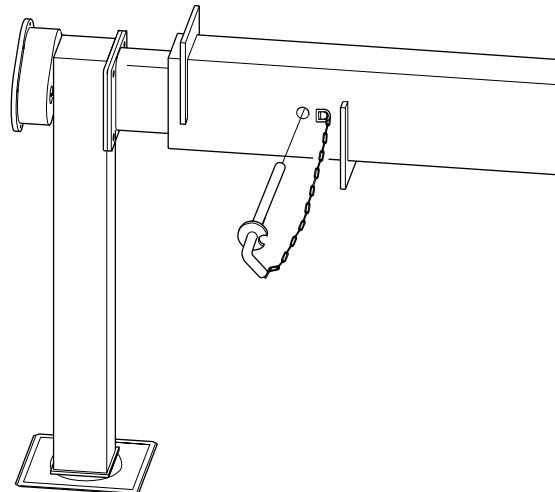

Fig.6-16 Locking pin outrigger chassis

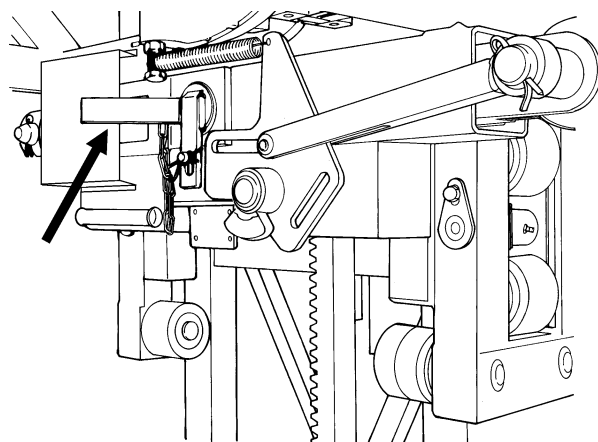

Fig.6-17 Autolevel locking pin

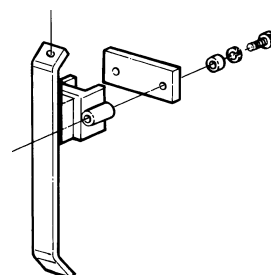

Fig.6-18 Lower striker plate

7. Assemble the platform components, by both chassis simultaneously on both sides of the drive units until the desired length is attained. The platforms may not exceed the maximum length.
8. Tighten the platform bolts until the specified torque is applied.
9. Push the second chassis towards the first and fix the platform elements together.
10. Repeat steps 3 to 5 for the second chassis.
11. The width of the platform can be adjusted to fit the form of the façade. See section 6.6.
12. Mount the steps and secure them with locking pins.
13. Mount the fencing and secure it with "hairpins".

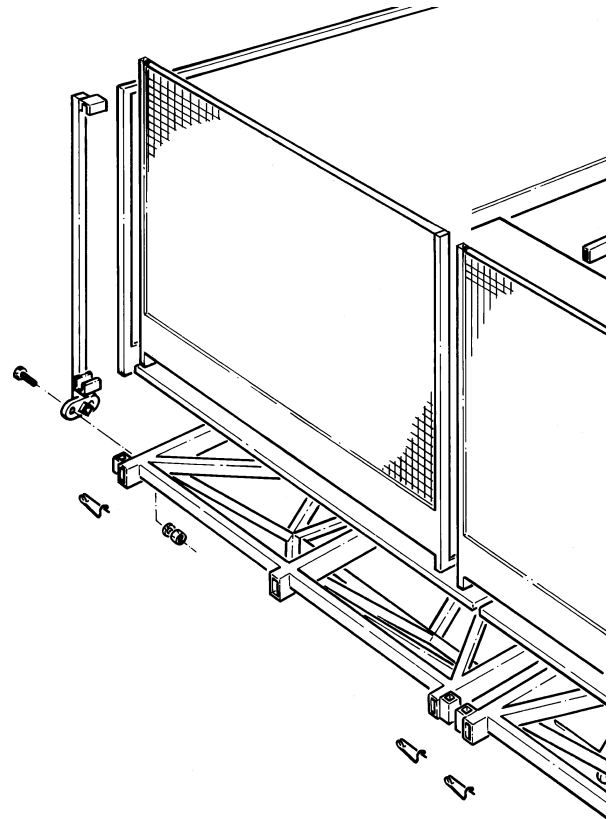

Fig.6-20 Fence

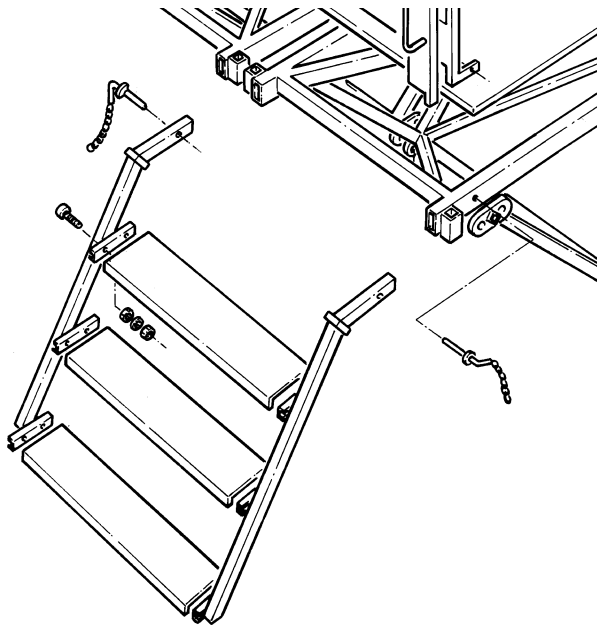
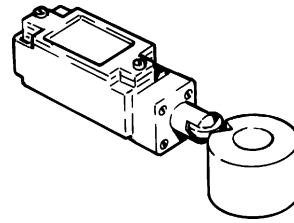
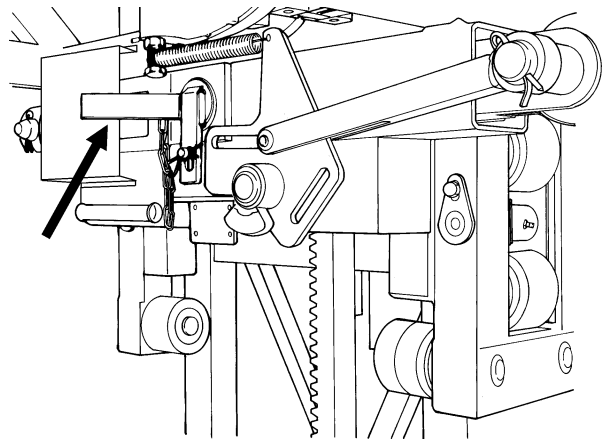

Fig.6-19 Step

14. Mount the gate and the cam for the gate safety switch. The roller must fall into the cam when the gate is closed
15. Remove the autolevel locking pins from both machines.
16. Remove the dummy plugs from the control cable sockets.
17. Connect the control cable and the electrical power supply cable. Secure the cables to the underside of the platform neatly so that they do not hang down.



*Fig.6-21 Gate safety switch*



*Fig.6-22 Autolevel locking pin*

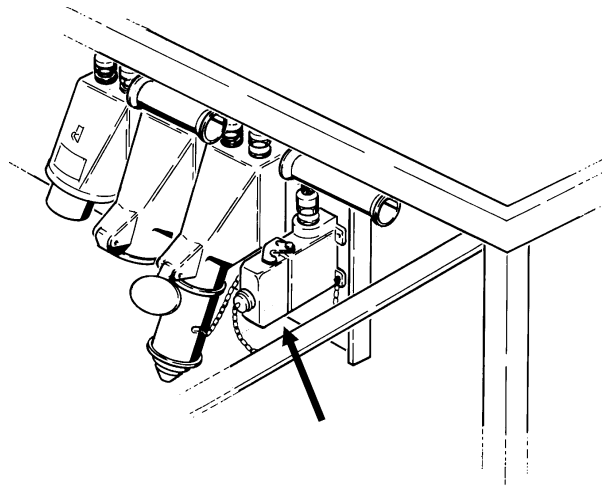

*Fig.6-23 Control cable dummy plug*

### 6.3.4 Mast climbing work platform with two masts on ground frames



One drive unit must be adjusted for "left" and the other for "right".

1. Check that the left-hand machine is adjusted for "left" and the right-hand machine for "right". See section 6.7.
2. Position the ground frames parallel to the wall and with a separation to allow for the required distance between the masts.
3. Place the ground supports for both ground frames.
4. Level the machine using the jacks. Ensure that the mast is vertical in both directions by checking with a spirit level (with a length of at least 1 metre / 40 inch) placed against two adjacent sides of the mast. Place wooden packing under the machine to provide optimum load spreading and stability.
5. Check that the autolevel locking pins for securing the parallel movement and the lower striker plates are mounted.
6. Assemble the platform components sequentially on both sides of the drive units until the desired length is attained. The platform may not exceed the maximum length.
7. Tighten the platform bolts until the specified torque is applied.
8. Assemble the second ground frame to the first by fixing the platform elements together.

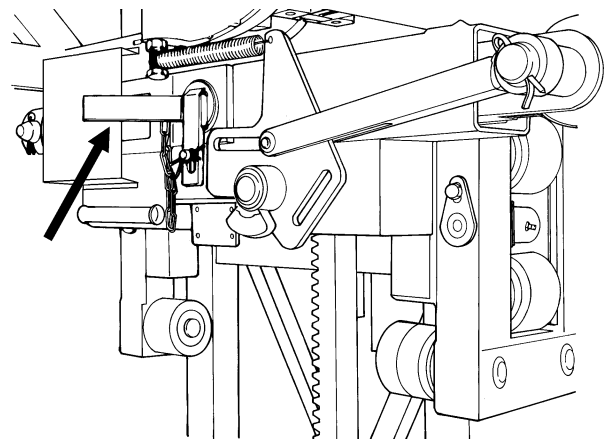

Fig.6-24 Autolevel locking pin

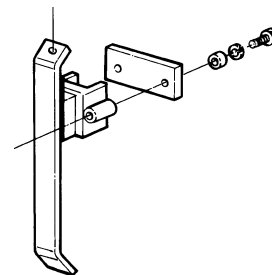

Fig.6-25 Lower striker plate

9. The width of the platform can be adjusted to fit the form of the façade. See section 6.6.
10. Mount the steps and secure them with locking pins.
11. Mount the fencing and secure it with "hairpins".
12. Mount the gate and the cam for the gate safety switch. The roller must fall into the cam when the gate is closed.

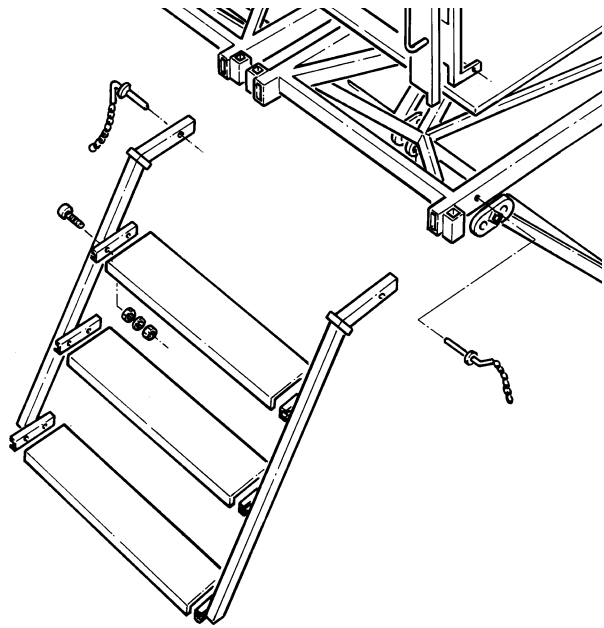

Fig.6-27 Step

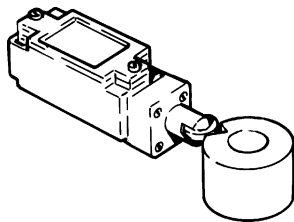

Fig.6-26 Gate safety switch

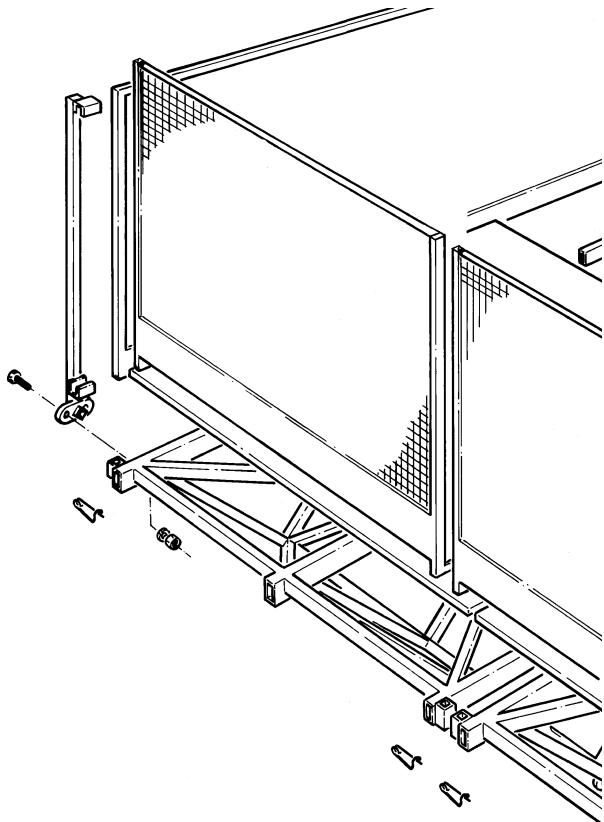
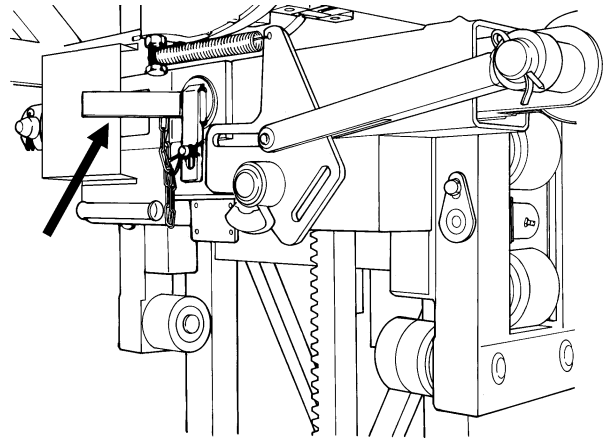
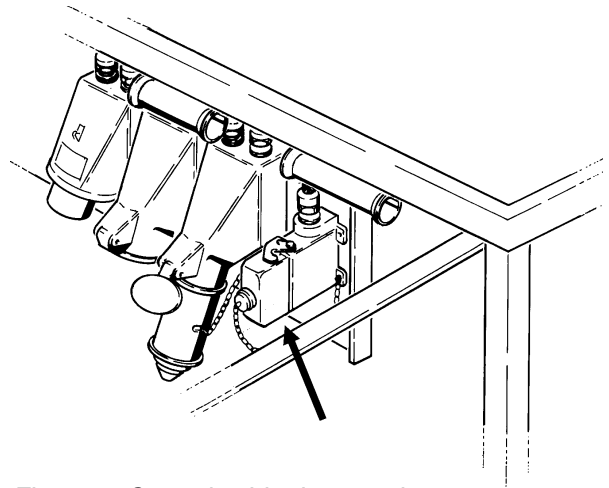

Fig.6-28 Fence

13. Remove the autolevel locking pins from both machines.
14. Remove the dummy connecting plugs from the control cable sockets.
15. Connect the control cable and the electrical power supply cable. Secure the cables to the underside of the platform neatly so that they do not hang down.



*Fig.6-29 Autolevel locking pin*



*Fig.6-30 Control cable dummy plug*

## 6.4 Assembly of the mast



If work has to be stopped, always complete the phase being worked on. Tighten all the bolts used for the last attachment and switch off and secure the main switch so that the machine cannot be operated.



As the assembly proceeds, place the anchor tubes, anchors and cable guides as described in section 6.5



Note that the power supply consists of 3 x 400 V + neutral + safety earth.



The mast(s) must always be assembled vertically.



In winds of strengths above 6 Beaufort (12,5 m/s) (41 ft/s) the machine may not be assembled.

1. Connect the power supply to the machine.
2. Set the main switch in position I or II (the position depends on the direction of phase rotation of the power supply). If the display shows code 02 and the phaselight on the phaseguard relay does not burn, set the main switch in the other position. The display must show code 00 and the phase light will be burning.

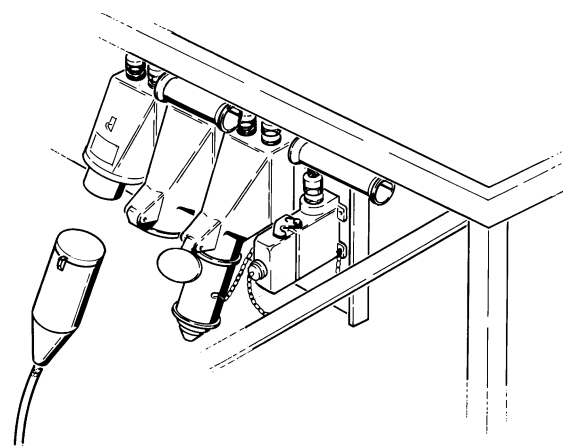

Fig.6-31 Power supply

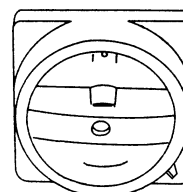

Fig.6-32 Main switch

3. When the mast climbing work platform is delivered it is in the buffer. In order to remove the mobile work platform out of the buffer, carry out the following procedure:

- 1 Press the push-button "reset positioning" and keep it pushed in.
- 2 Press the push-button "UP".

For a two-mast construction, check that the lower striker plates and the autolevel switches are properly adjusted. See sections 6.8 and 6.9.

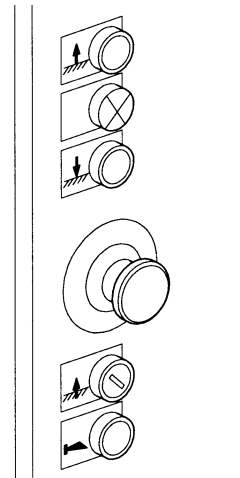

Fig.6-33 Control buttons

4. The mast climbing work platform is raised and lowered by pressing the UP and DOWN push buttons. When the push-button is released, the mast climbing work platform stops. In addition, an emergency stop push-button is provided. When this button is pushed, the power of the motors will be shut off.
5. Check that the proximity switch is mounted on both drive units.
6. Use a fork-lift truck or crane to raise the mast elements onto the platform. Ensure that the maximum loading permitted during assembly is not exceeded.
7. Stand on the platform and use the crane to place a mast element on the last element assembled. Secure the mast element with four bolts, washers and nuts. Tighten the bolts to the specified torque value. (See chapter 1)

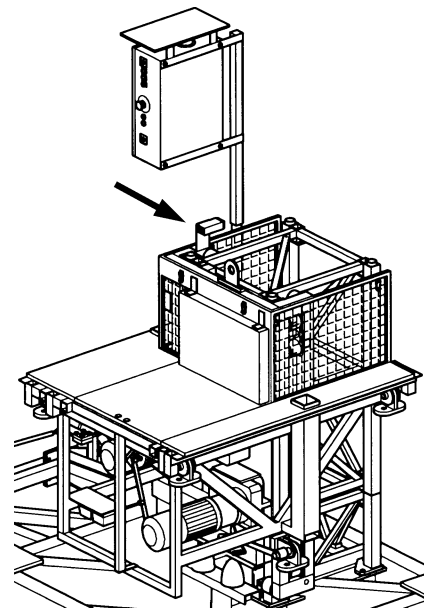

Fig.6-34 Proximity switch

8. Raise the platform towards the top of the mast element and repeat the procedure until another element must be assembled. Plan the procedure so that, when an anchor must be fitted, the loading of material and mast elements is a minimum.
9. Ensure that anchors are placed at the specified intervals.
10. Repeat this working method until the mast has reached the required height. The last element assembled must always be the red top element. The maximum specified height must not be exceeded.
11. If a crane is available on the building site, the mast can be more quickly assembled. Up to five mast elements can be assembled on the ground and then raised into position with the crane.
12. The mast must not extend too far above the uppermost anchor (See chapter 1). To achieve good stability, it is always better to place an anchor as close to the top of the mast as possible.
13. Assemble the mast cover panels from the platform and secure them.
14. The assembly is now complete. The assembly must now be tested as described in section 7.1

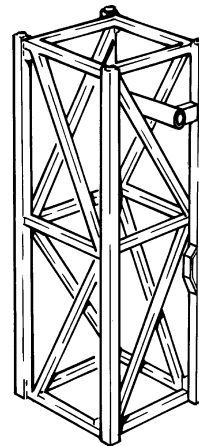

Fig.6-35 Red top mast element

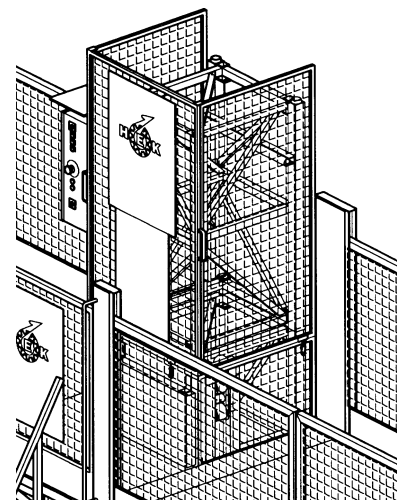

Fig.6-36 Mast cover

## 6.5 Anchoring the mast



If work must be stopped, always complete the current phase before stopping. Tighten all the bolts for the latest fixture and secure the main switch so that the mast climbing work platform cannot be operated.



Before starting to fix any anchors, ensure that the chassis/ ground frame is level.



The wall must be of such a quality that it can accept the forces applied to it via the anchors.



The platform extensions and the anchors must not come into contact during raising and lowering.

The anchor forces must be approved by the owner or the person responsible for the building to which the machine will be anchored.

1. Check that the mast is vertical with a spirit level at least 1 metre / 40 inch long. Recheck as each anchor is secured.
2. The mast must be anchored to the building at the distances specified in the table in chapter 1.
3. The anchors are assembled from mast adapters, horizontal anchor tubes and a support tube.

4. The horizontal anchor tubes and the support tubes can be supplied in various lengths.
  
5. Fixing the anchors:
  - Anchoring is carried out using bolt couplings, nut and bolt fastenings and washers. If conditions make it necessary, use may be made of other approved attachment materials which are suitable for the forces present. (Consult your dealer).
  - Cemented-in anchors must be allowed to become fully secure (the cement must have time to harden) before the mast climbing work platform is assembled. The cement or concrete used must be in accord with the specifications.
  - If chemical anchors or expansion bolts are used, these must be approved and must be able to withstand the forces involved.
  - Specifications for these types of bolts are available from the supplier. Permission to use them must be obtained from the local authorities.

#### 6. Securing the anchors:

- Secure the mast adapters (1) to the mast.
- Fix the wall plates (2) to the building.
- Secure the horizontal anchor tubes (3) between the mast adapters and the wall plates.
- Tighten the horizontal anchor tube couplings to the correct torque value.
- Use the adjustment construction to set the mast vertical and parallel to the building.
- Fix the support tube (4).

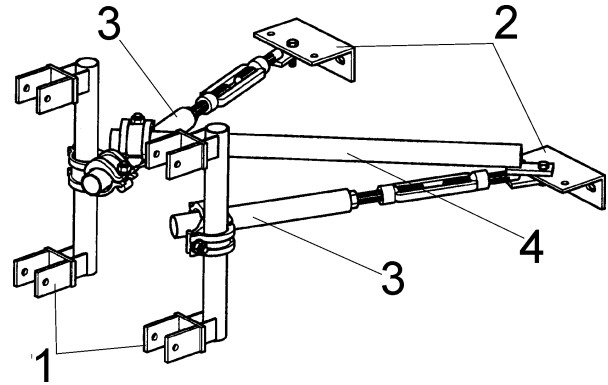

Fig.6-37 Anchoring

### 6.6 Adjusting the platform width

The width of the platform can be adjusted to the shape of the building. As standard an extension of 1 metre / 3.3 ft is possible. In case work must carry out behind the mast a anchor ramp must be mounted.



The planks used for adjusting the platform must in every case be secured in every direction.



The platform widening and the mast anchors must not come into contact when the platform is raised and lowered.



A fence (height 1.10 m / 43.3 in) completely surrounding the platform is compulsory. If the distance between the platform and the facade is 0.3 m - 0.5 m / 11.8 in - 19.7 in a fence with a height of 0.7 m / 27.6 in can be used. If the distance between the platform and the facade is less than 0.3 m / 11.8 in a fence is not compulsory but in this case a kick board with an height of 0,15m / 5.9 in must be fitted.

The platform extension must be in accordance with specification prEN1495. The platform extension must be fabricated from a non-slip, easily cleaned material. The extension must be self draining. The width of any openings or gaps in the floor must be sufficiently narrow that a ball with a diameter of 15mm will not pass through. The platform extension must be able to withstand a static load of 200kg / 440 lb on an square area of 0.1x0.1m / 0.4 x 0.4 inch on the least favourable part of the floor surface without causing any permanent distortion.

1. Pull out the outriggers and secure them with locking pins.
2. Cover the outriggers with planks.
3. Fix cross strips with a right-angle profile to the underside of the planking and secure them to the outriggers.
4. Mount the anchor ramp to the outriggers.

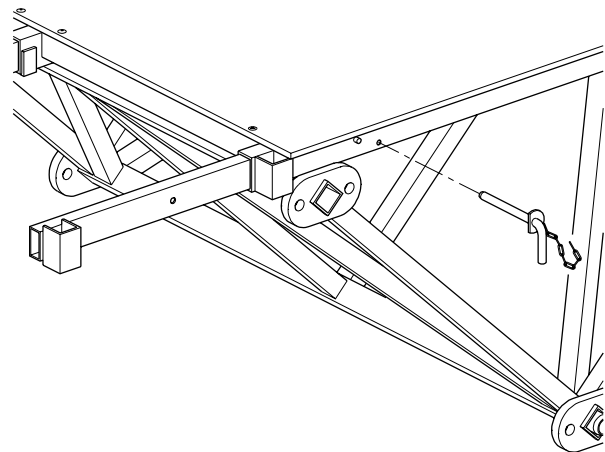

Fig.6-38 Outrigger platform extension

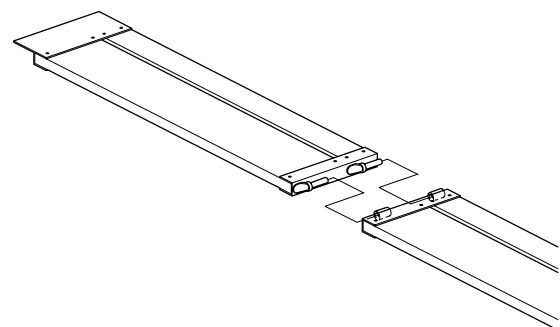

Fig.6-39 Anchor ramp

## 6.7 Setting the machine left or right

The factory setting is stated on the type plate fixed to the control box. An "R" in the machine number indicates right and an "L" indicated left.

The setting can be adjusted in the following way.

1. Insert the operating bar of the parallel movement mechanism in the required slot (left or right).
2. Set the switch on the control box in the required position (left or right).

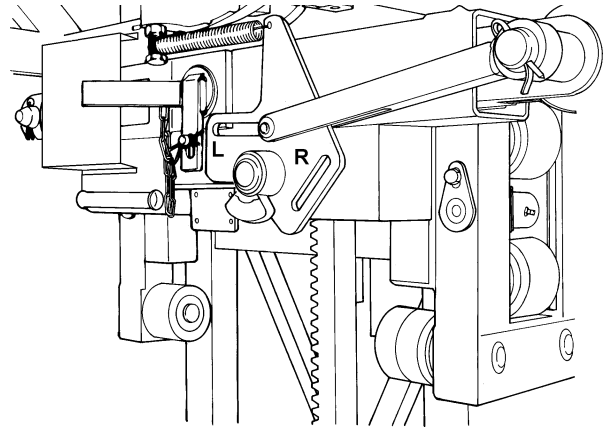

Fig.6-40 Machine setting left

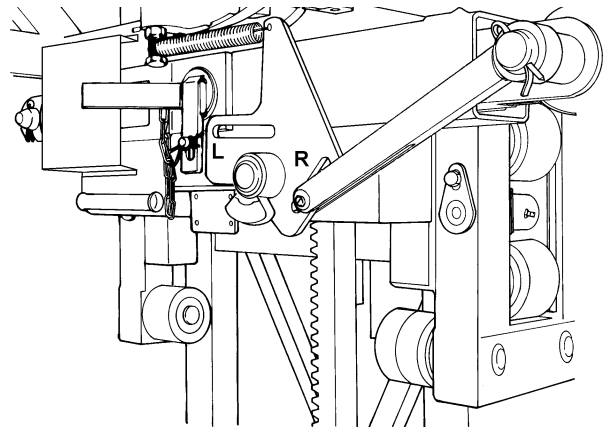

Fig.6-41 machine setting right

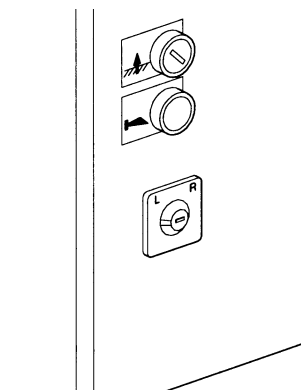
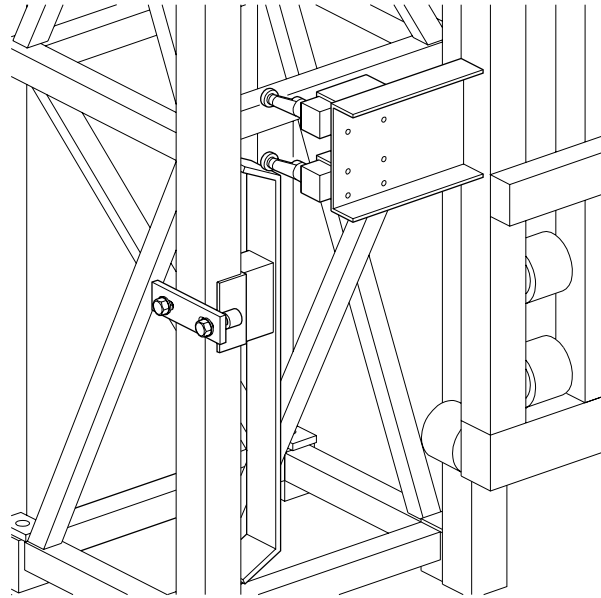

Fig.6-42 switch left/right setting

## 6.8 Checking and adjusting the lower striker plates

For a two-mast construction, the striker plates must be checked and if necessary, adjusted.

1. Lower the highest placed unit until the limit switch just touches the lower striker plates.
2. Use the other unit to level the platform.
3. Check that the limit switch just touches the lower striker plate for this unit.
4. If the lower striker plate does not touch the limit switch, adjust the position of the striker plate until it just touches the limit switch.
5. Check the adjustment.



*Fig.6-43 Adjusting lower striker plate*

## 6.9 Checking the autolevel switches

For a twin mast construction, the autolevel switches must be checked and adjusted if necessary.

1. Raise the platform by 3 metres / 9.8 ft and level the platform by means of the brake lever.
2. Operate the brake release on one drive unit and, depending on the distance between the centres of the masts, allow the unit to descend.
  - Distance between centres 730 cm / 24 ft : 25,5 cm / 10.0 in lower.
  - Distance between centres 1330 cm / 43.6 ft: 46 cm / 18.1 in lower.
 These distances represent a platform slope of 2 degrees.
3. Operate the "UP" push-button on the platform. The lowest unit must now be the first to rise.
4. Repeat the previous steps for the other unit.
5. If necessary, adjust the switches.

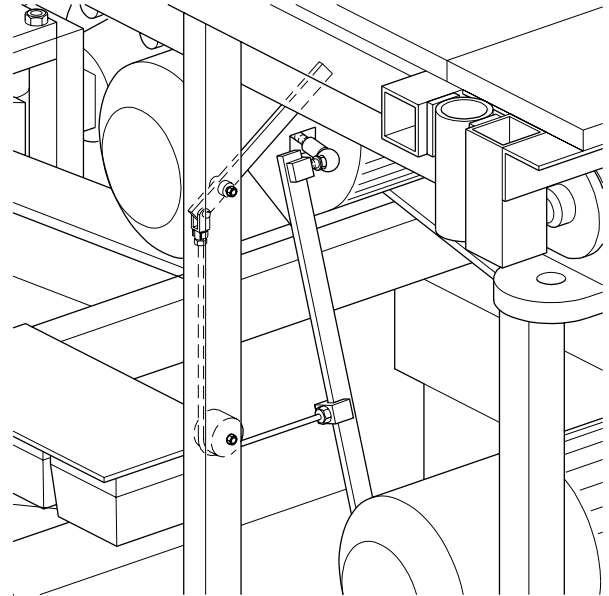

Fig.6-44 Brake lever drive unit

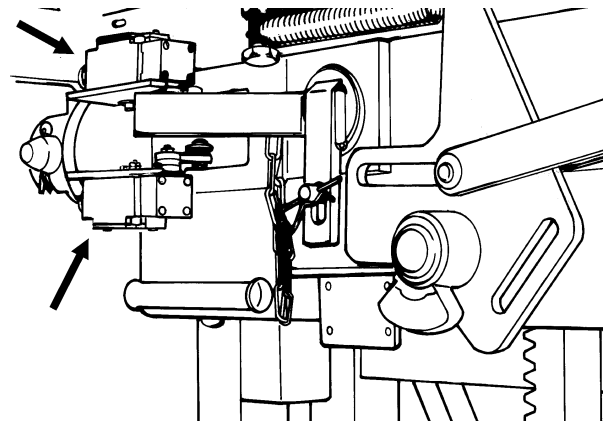

Fig.6-45 Autolevel switches

### 6.10 Adjusting the EMOS system

1. The switch can only be turned with the correct key. Set the EMOS switch (1,2,3) in position 2. The config panel starts to flash.
2. The program can be changed with the UP or DOWN button on the control box.
3. Set the desired program (See table chapter 1.7).
4. Set the EMOS switch on position 1.
5. The config panel shows the adjusted value.
6. Remove the key.

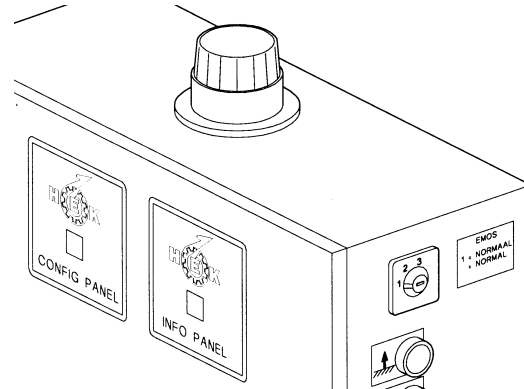

Fig.6-46 Adjusting EMOS

### 6.11 Lightning protection

1. Fasten the connecting cable between the chassis/ground frame and the mast.  
Cable specifications:  
- Insulated copper, 16 mm<sup>2</sup> cross section.
2. Mount the connection between the chassis/ground frame and the earth. This connection must satisfy the following specification:  
DIN VDE 0185, part II, §5.2  
The cable supplied (25 mm<sup>2</sup> / 0.0039 in<sup>2</sup> cross section, 25 m / 82 ft long) must be connected to the terminal box on the building site.

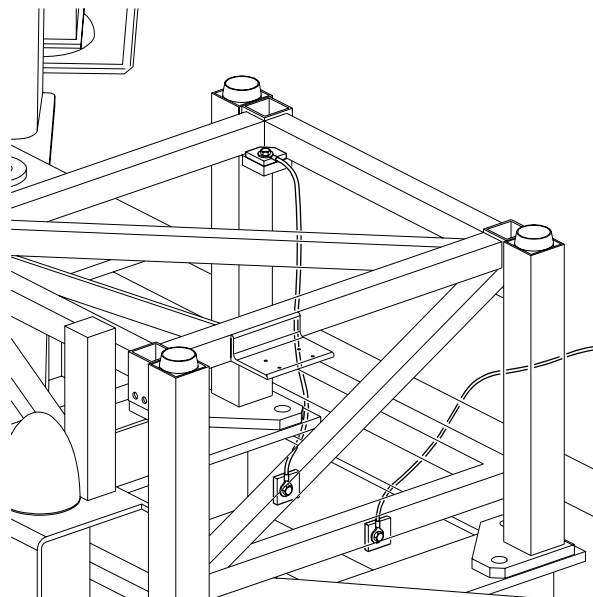

Fig.6-47 Lightning protection

## 7. OPERATION

### 7.1 General



No person may stand under the machine while it is in use.



Material may never extend beyond the edges of the platform. Items which can roll must be properly secured. The load may never be supported against the fencing.

The maximum reaction force (for instance caused by tools) of the platform with regard to the facade amounts for a single mast machine 500 N / 113 lbf and for a twin mast machine 800 N / 180 lbf.



When work stops for any reason, the main switch must be secured with the padlock.



During rising or descending no person may stand on the platform extensions.

### 7.2 Preparation

1. Before the mast climbing work platform is used it must be visually inspected (daily if it is used every day) for:
  - anchors and cable guides
  - presence of all security devices
  - connection between mast elements
  - position of the masts
  - any loose components

- ground supports and the quality of the ground
- electrical connections
- protective covers (presence and securing)
- securing of the platform extension
- operation of the limit switches
- no obstacles in the path of the platform
- oil leaking from the drive units and chassis motor
- functioning of the motor brakes (section 7.4).

2. Connect the electrical power supply.
3. Close the gates.
4. Remove the padlock from the main switch.

5. Place the main switch in position I or II (the position depends on the direction of phase rotation of the power supply).

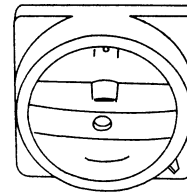

Fig.7-1 Main switch

6. Check that the EMERGENCY push-button on the control box is switched off (the push-button must be pulled out). On a twin mast unit release both emergency push buttons.

7. If the display shows code 02 and the phaseguard light does not burn, the main switch must be set in the other position. The display will show code 00. If the electric safety circuit (gates, etc.) is closed the blue light on the control box will burn.

Only single-mast. Eccentric overload check:

During a few seconds there will be sounding a buzzer and a light will flash on the control box.

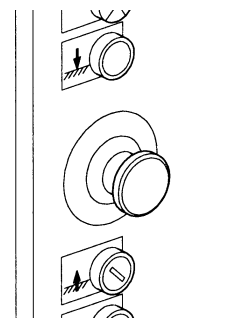

Fig.7-2 Emergency push-button

8. If a two-mast construction is used with two different types of Control boxes (one with a display and one without), the ON push-button must be pressed each time the platform is raised or lowered. If the platform must be controlled by the control box without a display.

### 7.3 Testing

1. Test the platform and check the following:
  - all limit switches, striker plates and safety devices and ensure that everything is properly adjusted.
  - that the path of the platform is not obstructed.
  - the functioning of all the push buttons on the control box.
  - the free movement of the power supply cable.

Also test the platform brakes. (see section 7.4)

### 7.4 Brake test

The brake test must be carried out daily.

1. Release the brake on one of the motors by pulling the lever on the motor. The platform may not descend. Release the brake lever.
2. Release the other brake. The platform should not descend. Release the brake lever.

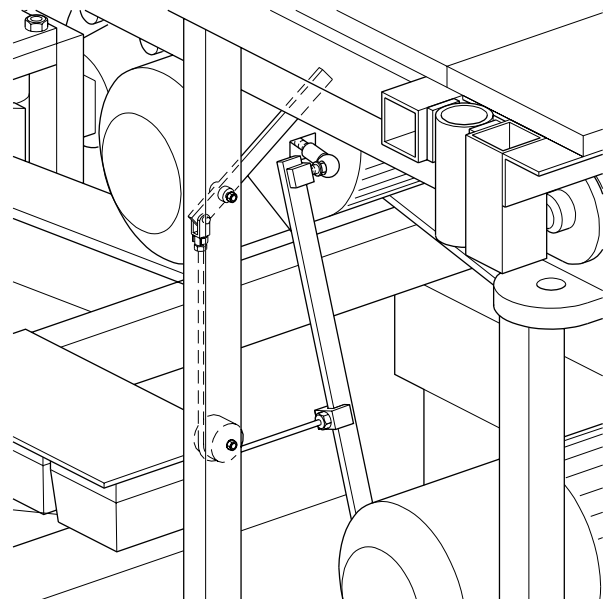

Fig.7-3 Brake lever drive unit

3. Repeat the previous two steps for the other drive unit.



If the platform descends, the mast climbing work platform must not be used. Consult the service engineer.

### 7.5 Operation from the platform

**UP:** If this push-button is pressed, the platform is raised. When the push-button is released, the platform stops immediately.

**DOWN:** If this push-button is pressed, the platform is lowered. When the push-button is released, the platform stops immediately.

**EMERGENCY:** When this push-button is pressed, the platform is locked.

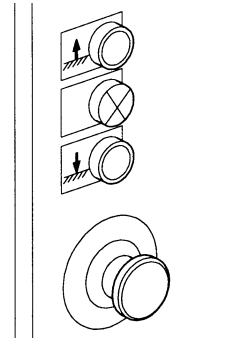

Fig.7-4 Push-buttons control box

### 7.6 Operation in an emergency situation

In an emergency, for example in the event of a power failure, the platform can always be lowered.

- Using the malfunction analysis in chapter 10, try to solve the problem. If the problem can not be solved it is possible to make a emergency descent in the following way.

1. Open the trap door in the platform.
2. Remove the toolbox.
3. The motors have a lever which permits the brake to be released.
4. When this lever is operated, the platform will begin to descend. For a two-mast construction, the brakes must be released by two persons simultaneously so a clear system must exist between them.

The speed of descent will be limited by the centrifugal brake.



After a maximum descent of 5 metres / 16.4 ft, stop the platform for 2 minutes in order to avoid the centrifugal brakes becoming overheated, which will result in their working less efficiently.

5. For a two-mast construction, take the opportunity during the stop situation the set the platform level with the aid of the brake release mechanisms. If the platform becomes excessively inclined, the autolevel safety system will come into operation. In this event, external help will be required.

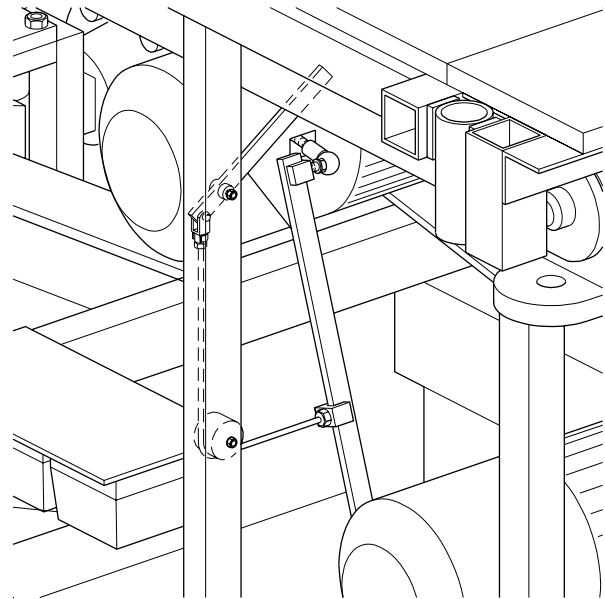

*Fig.7-5 Drive unit brake release*

## 7.7 Eccentric overload device

The MSHF mast climbing work platform is provided with an eccentric overload device. The eccentric overload device is only active in a single-mast construction.

When the platform is eccentric overloaded to 90%, the light on top of the control box starts to burn.

When the platform is eccentric overloaded to 100%, the light on top of the control box will burn and a buzzer will sound. In this situation the machine can not be operated.

When the cause of overload is removed the eccentric overload device will be reset automatically.

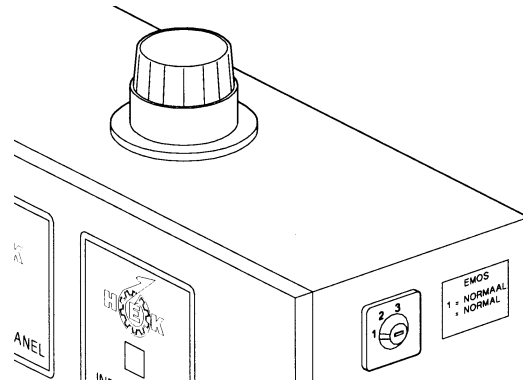

Fig.7-6 Signal light

## 8. DISASSEMBLY AND TRANSPORT



Ensure that the maximum loading allowed during assembly is not exceeded.



In winds of strengths above 6 Beaufort (12,5 m/s) (41 ft/s), the machine may not be disassembled.

1. Remove the mast guards.
2. Disassemble the mast elements above the uppermost anchor. Before loosening the uppermost anchor, lower the disassembled elements to the ground. Now disconnect the uppermost anchor.
3. Together with the disassembly of the mast, the anchor tubes, the anchors and the cable guides must be disassembled.
4. If a crane is available on the building site, the mast can be more quickly disassembled. As many as five mast elements can be removed together and lowered to the ground with the crane. The mast elements can further disassembled on the ground.
5. Repeat this procedure until the mast, with the platform in its lowest position, has been completely disassembled.
6. Release the brakes and allow the platform to descend onto the buffers.

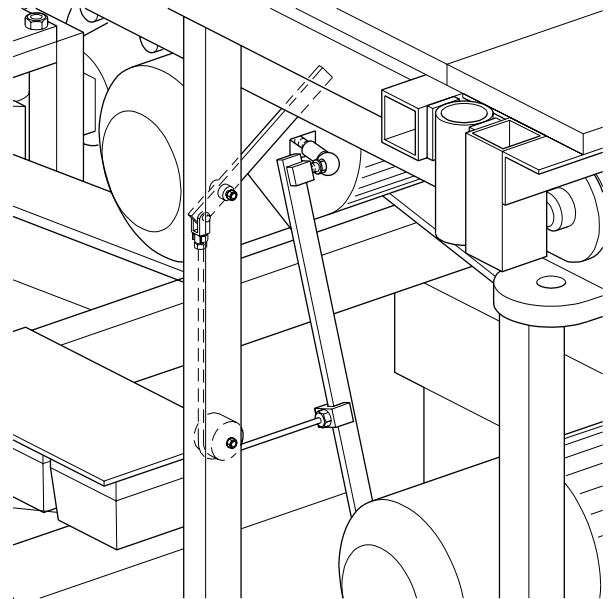

Fig.8-1 Drive unit brake release

7. Insert the locking pins in the autolevel devices and secure them.
8. Disconnect the electrical supplies and replace the control cable dummy plug (for a twin mast construction).
9. Raise the jacks and remove the ground supports.
10. Remove the control box.

There are two possible ways to transport the basic machine. This can be done with or without the platform elements being attached. The transport method depends on the dimensions of the platform and the widths and lengths of vehicles permitted by national regulations.

If the basic machine is too large to be transported in one piece, take the following steps.

11. Disassemble the fences, the gates and the gate posts.
12. Disassemble the platform extensions. Slide in the outriggers and secure them.

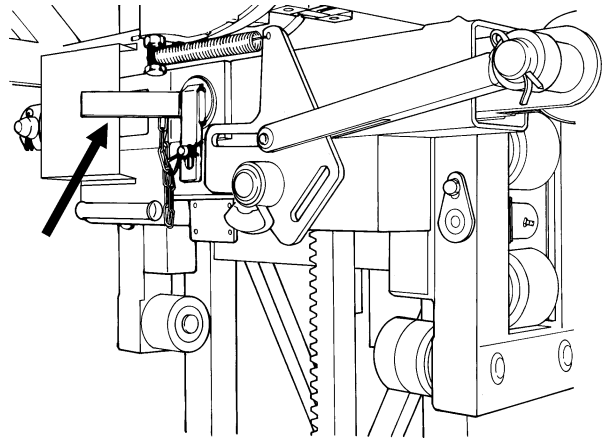

Fig.8-2 Autolevel locking locking pin

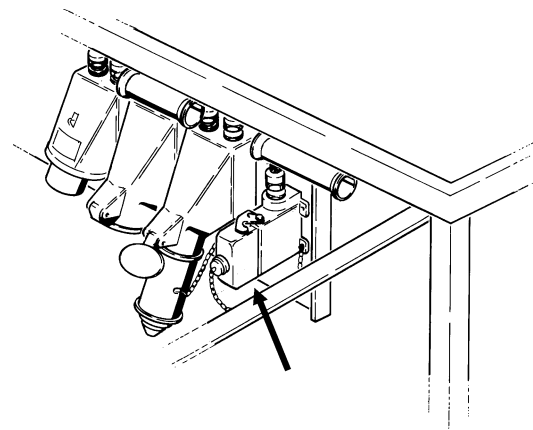

Fig.8-3 Control cable dummy plug

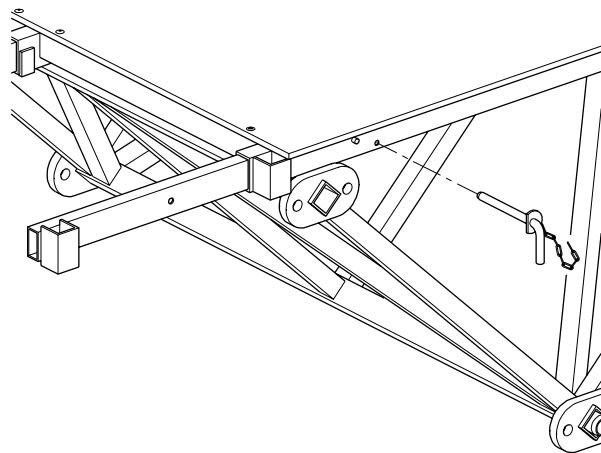
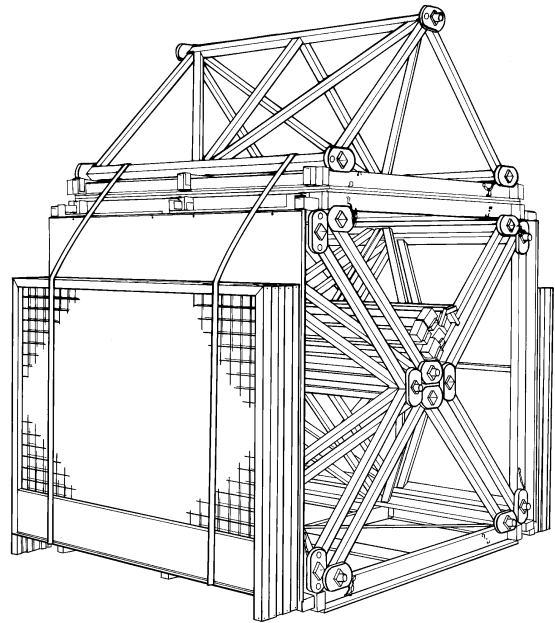
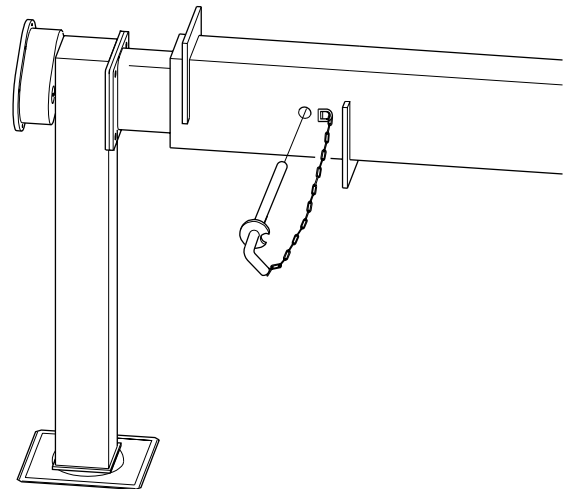

Fig.8-4 Securing outrigger

13. Disassemble the platform elements. During the disassembly of the platform elements, care must be taken that the machine remains in balance. Support the platform if necessary.
14. The platform elements can be packed in bundles of five.
15. Slide in the outriggers of the chassis and secure them.



*Fig.8-5 Bundle platform elements*



*Fig.8-6 Locking pin outrigger*



## 9. MAINTENANCE

### 9.1 General

The simple robust construction of the machine ensures that maintenance can be kept to a minimum. Sensible use of the machine, regular checks for correct functioning and regular cleaning will result in a minimum requirement for maintenance. This will guarantee a long working life for the mast climbing work platform.

Parts must comply with to the technical specification of Hek Manufacturing b.v.!  
Use only original parts of Hek Manufacturing b.v.

### 9.2 Maintenance intervals

The following maintenance activities are essential:

#### A. Weekly maintenance

- Grease the rack and pinion. If these are heavily contaminated with sand or grit they must be cleaned first.  
Specification for grease:
  - HEK-rack and pinion grease
  - Shell Rhodina 2
- Clean the platform and the drive unit.
- Carry out the checks detailed in section 7.2.
- Visually inspect the rack and pinion drive.

#### B. Monthly maintenance

- Inspect the guide rollers (visual inspection of security devices, gaskets and bearings).
- Check that all mast bolts are tightened with the correct torque.
- Check that all anchors are secure and re-secure any loose parts.
- Check the functioning of all limit switches.
- Grease the jacks and the king pins of the chassis.
- Grease the drive unit pressure rollers.
- Perform the activities listed at A.

C. Quarterly maintenance

- Check the motor brake (see section 9.4.2)
- Check the play in the guide rollers.
- Check the rack and pinion (visual).
- Perform the activities listed at A and B.
- For a mast climbing work platform with twin masts, check the operation of the autolevel device (see section 9.3).

D. Annual maintenance

- Check that the platform elements are tightened with the correct torque.
- Check the rack fixing bolts.
- General inspection of paintwork, corrosion and welds.
- Perform the activities listed at A, B, and C.
- Eccentric overload mechanism
  - remove the eccentric mechanism.
  - clean the eccentric mechanism.
  - grease the moving parts and reinstall the mechanism.
- Check all welds of the mast climbing work platform.

E. Biennial maintenance

- Change the oil in the drive unit reduction gearbox. Lubricant specification for STEPHAN motors:  
According to DIN 51502, kinetic viscosity acc. to DIN 51562 of approx. 220 mm<sup>2</sup>/sec.
  - Aral Degol BMB
  - Shell Macoma W 71
  - Esso Vartan 220
- Re-grease the bearing of the reduction gearboxes.
- Perform the activities listed at A, B, C and D.

F. Maintenance during storage of the machine

- Inspect the machine in its entirety.
- Check all vital parts and replace any which have become damaged.
- Clean and grease the rack and pinion drive.
- Inspect the mast elements (with the racks) and check that all separate connection pieces are in order.
- Check the lowest mast bolts for corrosion and replace them if necessary.
- Cover the basic machine with a tarpaulin; in every case, cover the control boxes and the limit switches.
- Screw out the jack of the chassis so that it does not rest on its wheels.
- For long-term storage, consult your dealer.

### 9.3 Autolevel mechanism check

1. Raise the platform by three metres.
2. Operate the brake release mechanism on one drive unit. The autolevel safety mechanism must now operate.
3. Set the platform back in the horizontal position with the "UP" push-button.
4. Repeat the previous step for the other unit.
5. If the autolevel safety mechanism does not function correctly, the mast climbing work platform must not be used! Consult your service engineer.

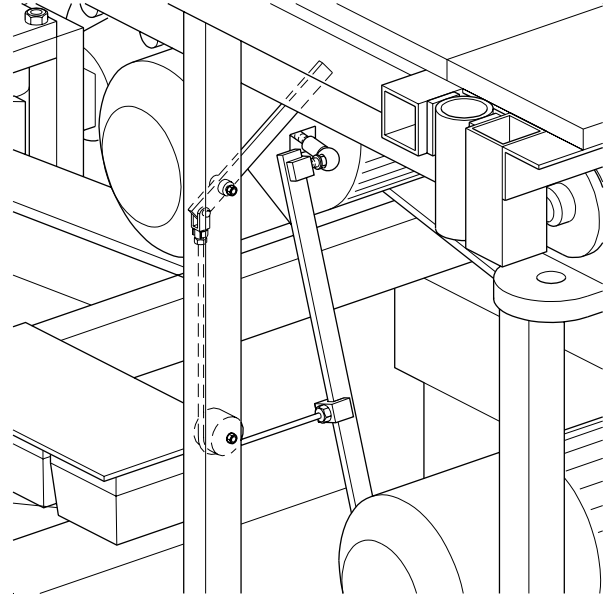

Fig.9-1 Drive unit brake release

### 9.4 The motor brake

The motor has a built-in electromagnetic brake. This brake functions according to the "normally ON" principle, that is, when the motor has no power supply the brake is active and the motor shaft will be braked. ( $n = 0 \text{ rev./min}$ ).

The braking effect is achieved by friction between several discs and the brake must be used "dry" (not greased).

### 9.4.1 Operation

The brake mechanism has a metal rotor (3) with friction material on both sides. Four pressure springs (5) in the stator exert an axial force on an anchor plate (2). This anchor plate is pressed by the spring force against rotor. The rotor is mounted on the motor shaft in such a way that it can slide in an axial direction along the shaft. Because the anchor plate presses against the rotor, the rotor is pressed against the friction plate (6). The contact between the friction material on either side of the rotor, the anchor plate and the friction plate results in the required braking effect.

The stator has a built-in braking coil (1) which produces a strong magnetic field when a DC current is applied to it.

When the brake is to be released, a current is made to flow through the braking coil. The resulting magnetic field "pulls" the anchor disc toward the stator, thus releasing the brake.

It is also possible to release the brake manually. If the manual release lever is pressed in the direction indicated by the arrow on the cover, the anchor plate is moved against the spring pressure with the aid of two ball bolts, so that it is pressed towards the stator, releasing the brake.

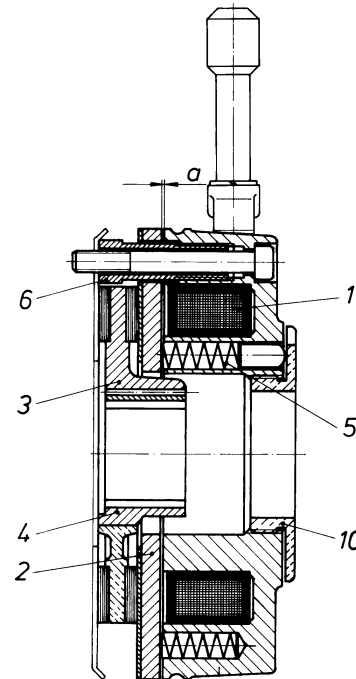

Fig.9-2 Motorbrake

### 9.4.2 Maintenance

In normal use the motor brake is more or less maintenance free. However, after frequent raising and lowering of the platform it may be necessary to adjust the air gap between the anchor disk and the stator, and if necessary, to replace the rotor.

In order to check the condition of the brake, the width of the air gap "a" and the thickness of the friction material on the rotor must be measured every three months.

The air gap "a" is adjusted by the manufacturer to 0.3 mm / 0.012 in and must never be more than 0.9 mm / 0.035 in. The total thickness of the rotor (including the friction material) must not be less than 9.5 mm / 0.37 in.

To check:

1. Switch off the mast climbing work platform at the main switch and secure the switch with the padlock.
2. Remove the brake release mechanism using an open ended spanner.
3. Remove the fan cover from the motor.
4. Use a feeler gauge to measure the width of the air gap "a" close to the three hollow adjusting bolts (6).
5. Remove the rubber dust ring and use a vernier calliper gauge to measure the thickness of the rotor. Replace the rotor if the thickness is 9.5 mm / 0.37 in or less.

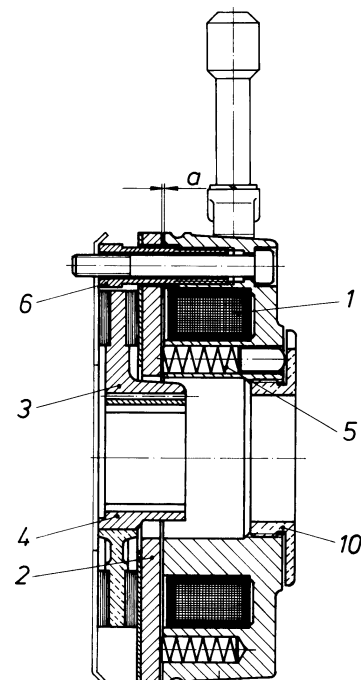

Fig.9-3 Motorbrake

6. Adjust the width of the air gap "a" as follows:
  - Use an open-ended spanner to turn the three hollow adjusting bolts (6) further into the stator. Ensure that these bolts are all screwed into the stator by the same amount.
  - Use a feeler gauge to measure the width of the air gap "a" close to each of adjusting bolts and turn the bolts until the gap by each bolt is just 0.3 mm / 0.012 in wide.



The adjustment of the hand release may not be changed, not even when air gap "a" is readjusted, as security can be adversely affected.

7. Mount the rubber dustring, the fan cover and the brake lever.

## 10. MALFUNCTION ANALYSIS

The control box on the platform has an "information panel". This "information panel" consists of a display on which fault codes appear in the event of a malfunction. An explanatory list of fault codes is attached to the control box as an aid to rapid and efficient fault repair. The following table gives an indication of the methods to be employed in the event of a malfunction.

Code	Description	Malfunction	Solution
01	Motor M1 & M2 thermal overload	<ul style="list-style-type: none"> <li>- Platform loading too high</li> <li>- Voltage too low</li> <li>- Motor stalled</li> </ul>	<ul style="list-style-type: none"> <li>- Reduce loading</li> <li>- Consult an electrician</li> <li>- Consult an electrician</li> </ul>
02	Phaseguard relay	<ul style="list-style-type: none"> <li>- Main switch incorrect position</li> </ul>	<ul style="list-style-type: none"> <li>- Set main switch in the other position; if the malfunction is not corrected, consult an electrician.</li> </ul>
03	Emergency stop pushbutton	<ul style="list-style-type: none"> <li>- Pushbutton depressed</li> </ul>	<ul style="list-style-type: none"> <li>- Rotate pushbutton to release</li> </ul>
04	Eccentric overload	<ul style="list-style-type: none"> <li>- Platform eccentrically overloaded</li> </ul>	<ul style="list-style-type: none"> <li>- Reduce loading</li> </ul>
05	Limiting switch bottom	<ul style="list-style-type: none"> <li>- The machine has run too far downward</li> </ul>	<ul style="list-style-type: none"> <li>- Consult an electrician</li> </ul>
06	Motor control unit	<ul style="list-style-type: none"> <li>- Motor control malfunction</li> </ul>	<ul style="list-style-type: none"> <li>- Switch off the main switch for 30 seconds and then on again; if the malfunction is not corrected, consult an electrician</li> </ul>
07	Limiting switch top	<ul style="list-style-type: none"> <li>- The machine has run too far upwards</li> </ul>	<ul style="list-style-type: none"> <li>- Consult an electrician</li> </ul>
08	Fall safe brake/other	<ul style="list-style-type: none"> <li>- Fall safe brake in operation</li> </ul>	<ul style="list-style-type: none"> <li>- Consult an engineer</li> </ul>
09	Gate/other	<ul style="list-style-type: none"> <li>- Gate is open</li> <li>- Connector not in socket</li> <li>- Switch defective or "sticking"</li> </ul>	<ul style="list-style-type: none"> <li>- Close the gate</li> <li>- Plug connector into socket</li> <li>- Check the switch</li> </ul>
12	Mast detection sensor	<ul style="list-style-type: none"> <li>- Machine run too far during assembly phase</li> <li>- Switch defective</li> </ul>	<ul style="list-style-type: none"> <li>- Move the machine downward; if the malfunction is not corrected, consult an electrician</li> </ul>
14	L/R malfunction	<ul style="list-style-type: none"> <li>- Fuse F104 deactivated</li> </ul>	<ul style="list-style-type: none"> <li>- Set machines Left and Right, activate fuse F104</li> </ul>

In all cases not covered by the above malfunction tables an electrician must be consulted.

Motor does not run	No power supply	<ul style="list-style-type: none"> <li>- Defective fuses in building site supply</li> <li>- Damaged cable</li> <li>- Motor safety relais switched off</li> <li>- Main switch defective</li> </ul>
	Voltage too low	<ul style="list-style-type: none"> <li>- Incorrect cable type</li> <li>- Cable is too long</li> </ul>
	42 Vac control voltage not present	<ul style="list-style-type: none"> <li>- Automatic fuses operated</li> </ul>
Voltage present but platform cannot be raised or lowered	Relays K102 en K103 are energized but platform does not move up or down	<ul style="list-style-type: none"> <li>- Motor brake locked</li> <li>- Adjust brake</li> </ul>
Other malfunctions	Brake distance too long	<ul style="list-style-type: none"> <li>- Wrong adjusting parralel movement protection</li> <li>- Adjust brake</li> </ul>
	The platform decends erratically	<ul style="list-style-type: none"> <li>- Minimum mast distance too little</li> </ul>
	The platform does not develop sufficient power	<ul style="list-style-type: none"> <li>- Inform your technical service or dealer</li> </ul>

In all cases not covered by the above malfunction tables an electrician must be consulted.

## 11. MACHINE DISPOSAL

### **General**

After a number of years of reliable service the life of every machine inevitably comes to an end. The machine must then be disposed of in an as environmentally friendly manner as possible.

Amongst others, the following possibilities present themselves:

- Part exchange for a new machine.
- Disposal by a recycling facility.
- Demolition.

### **Discarding the machine**

- Drain the oil out of the reduction gearbox and dispose of this via an authorized facility.
- Remove any usable parts.
- Dispose of the remainder via waste disposal facility.



## 12. LIST OF KEYWORDS

**A**

A-symmetrical configurations	1-8
Adjustment switch EMOS	5-2
Air gap	9-5
Anchor forces	1-14, 6-17
Anchor ramp	6-19
Anchoring	6-17
Assembly and anchoring	6-1
Autolevel mechanism	9-3
Autolevel switches	6-23

**B**

Blue control light	5-2
Brake test	7-3
Buffer	6-15
Built-in and additional safety features	3-3

**C**

Chassis drive unit	4-3
Concrete foundation	6-3
Config panel	5-2
Control cable	6-10, 6-13
Control components	5-1
Crane	2-1

**D**

Definition left and right	6-1
Dimensions	X
Disassembly and transport	8-1
Distance to the facade	6-4
Drive unit	2-1

**E**

EC Declaration of Conformity	VIII
Eccentric overload device	7-6
Electrical installation	1-5
Electrical power supply	6-2
Emergency push-button	5-2
Emergency situation	7-4
EMOS system	6-24

**F**

Fencing	6-4, 6-6, 6-7, 6-9, 6-12, 6-20
Foreword	V

**G**

Gate safety switch	6-6, 6-7, 6-10, 6-12
Ground pressure	6-3
Ground support	6-3

**H**

Hard road surface	6-3
Horn	5-2

**I**

Info panel	5-2
------------	-----

**K**

Keyswitch adjustment left/right	5-2
Keyswitch buffer	5-2

**L**

Lightning protection	6-24
Loaded and unloaded	4-1
Locking pin	6-5, 6-7, 6-8, 6-11
Lower striker plate	6-5, 6-7, 6-8, 6-11, 6-22

**M**

Machine disposal	11-1
Main switch	5-2
Maintenance	9-1
Maintenance intervals	9-1
Malfunction analysis	10-1
Mast	6-14
Mast cover	6-16
Motor brake	9-3

**O**

Operation	7-1
Outriggers	1-10

**P**

Parts	9-1
Platform control box	5-2
platform width	6-19
Positioning the mast climbing work platform	6-4
Power supply socket chassis	5-1
Power supply socket drive unit	5-1
Proximity switch	6-15
Push button DOWN	5-2
Push button UP	5-2

**R**

Reaction force	7-1
Repositioning on the building site	4-2
Repositioning with a crane	4-4



**S**

Safety	3-1
Safety after use	3-3
Safety in use	3-1
Safety prior to use	3-1
Scaffold coupling	1-14
Setting the machine left or right	6-21
Signal light	5-2
Special situations	1-1
Symbols	X
Symmetrical platform construction	1-8

**T**

Testing	7-3
Top element	6-16
Transport	4-1
Transport weight	4-4



